



Everything you need
to make your job easier!



Wheel Accessories for today's aftermarket

800 854-6770

Chrome Center Caps for OE Alloy Wheels
Hub Ring Specialists

IMPORTANT!

DON'T THROW THIS CATALOG AWAY!

Every custom wheel dealer needs the information contained in this catalog, even if you don't purchase our products.

Regardless of the brand name or type of custom wheels you sell, we all must deal with wheel accessory hardware.

Your customer may only need a replacement cap or lug nut, or you might be looking for a full stock of assorted products.

The problem is the same for both of you and your customers, which ones do I really need?

Most wheel accessory catalogs are often deceiving, offering only pictures, and few measurements.

The parts look like the one you want, but when you receive the product you find it is too tall, too short, or not the right diameter.

How can this catalog help you?

- * **Individual illustrations** of each different product.
- * **Life size drawings** of most parts let you actually compare and make the right choice.
- * **Detailed drawings** of wheel center caps show you exactly the diameter and height of each cap.
- * **Measuring guides** to help you decide exactly which items you want.
- * **Complete application guide** section included.
- * **Complete wheel installation guideline** included.
- * **Easy to read exact net pricing** on each item right in the catalog, no extra price list to fool with or discounts to calculate.

Copyright © (1994, 1999, 2003)
 HIDK INC d.b.a. Prestige Wheel Accessories and Prestige International, Huntington Beach, California.
 All rights reserved.

Neither this catalog nor any portion hereof may be reproduced in whole or in part without the express written authorization of Prestige Wheel Accessories. Infringement will be vigorously prosecuted (for all damages, profits, punitive damages, attorney fees and costs)[under United States and California Law (including but not limited to Titles 15 and 17 , United States and California Business and Professions Code 17200)].

Prestige (800) 854-6770 (877) LUG-NUTS
 WHEEL ACCESSORIES (714) 841-6333 5 8 4 - 6 8 8 7
 Fax: (714) 841-6413 M-F 7:30AM - 4:30PM CALIF TIME

TABLE OF CONTENTS

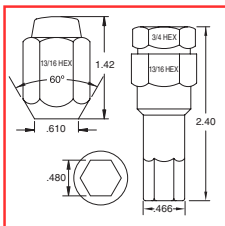

LUG NUTS (PGS. 5-15)

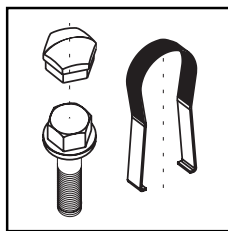

LUG NUT COVERS (PG. 16-17)

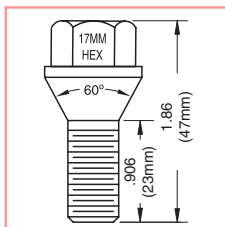

LUG BOLTS (PGS. 18-25)

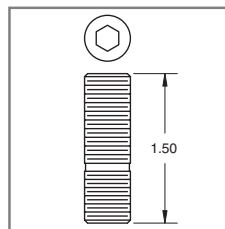

STUDS (PG. 26)

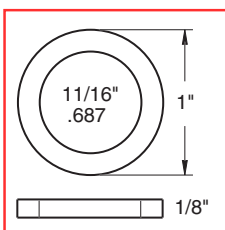

WASHERS (PG. 27)

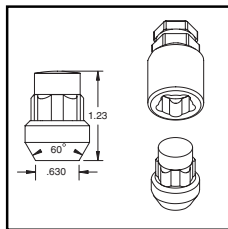

LOCKS (PGS. 28-31)

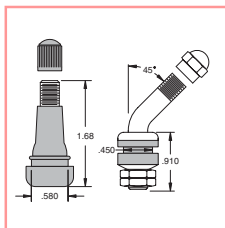

VALVE STEMS (PGS. 32-34)

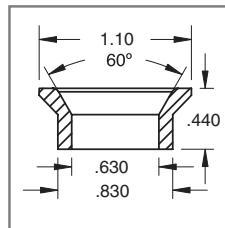

WHEEL INSERTS (PG. 35)

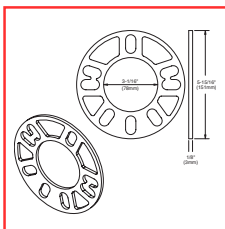

SPACERS (PGS. 36-41)

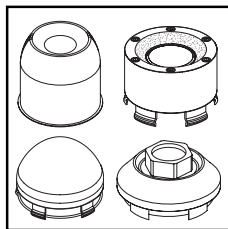

CAPS & CAP ACCESSORIES (PGS. 42-49)

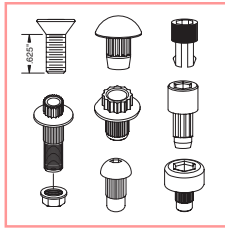

RIVETS/ASSEMBLY BOLTS/CAP LOCKS (PGS. 50-53)

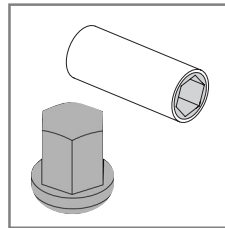

PORSCHE (PGS. 56)

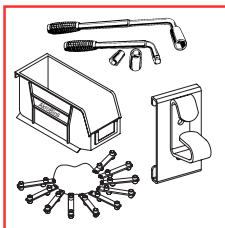

TOOLS & SALES AIDS (PGS. 57-63)

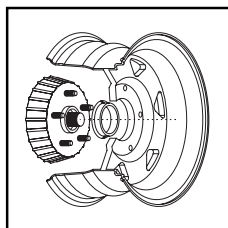

HUB CENTRIC RINGS (PGS. 66-69)

REFERENCE INFORMATION (PGS. 54-55, 64-65 & 70-84)

ORDERING/POLICIES

ORDERING INFORMATION & POLICIES

Our wholesale pricing is intended for those companies who are truly in an automotive related business. We reserve the right to refuse to sell to those companies who, in our opinion, are not qualified.

- ORDER SIZE:** The cost to process an order, regardless of size, is about the same. We will add a "small order" charge of \$10.00 to any order under \$50.00
- MOST products are prepackaged in specific quantities (i.e. MOST lug nuts are 100 per box). We will not break our normal packaging without a price adjustment.
- Check this CATALOG for standard packaging quantities.
- PRICING:** All pricing is based on current pricing that is in effect at the time of shipment. All invoices will be net priced. Any volume discount prices, special net quantity buys, freight allowances or c.o.d. payment discounts will be shown on the invoice. No other discounts are offered.
- As some of our products are affected by the changing foreign currency rates, we reserve the right to change pricing at any time and without prior notice.
- PAYMENT:** Cash ,cashiers check or credit card until your company check application has cleared. When your application is approved, then your company check will be accepted.
- CREDIT:** Credit is subject to management's approval. Until a charge account is set-up, all shipments will be on a C.O.D. basis. All credit privileges are subject to a periodic review.
- TERMS:** Based on order size, purchase frequency and credit approval, We offer the following payment terms:
- Credit Card (Visa or Mastercard).
 - C.O.D. Cash
 - Company Check with completed company check guarantee form.
 - Net 30 Days on approved credit application.
- ANY ACCOUNT WHO ALLOWS THEIR BILL TO BECOME 30 DAYS PAST DUE MORE THAN 3 TIMES WILL LOSE THEIR OPEN ACCOUNT CREDIT PRIVILEGES.**
- FREIGHT:** All orders will be shipped F.O.B. Huntington Beach, California. Unless specifically instructed by you, we will ship by the most convenient or economic way; normally by UPS.
- WARRANTY:** All products sold, are done so under the warranty policy of the actual manufacturer of the product. We offer or imply no other warranty.
- RETURNS:** All returns must have a return authorization number (RGA#). Returns without the RGA# clearly marked on the package will be refused. All returns must be freight prepaid, any freight collect shipments will be refused.

Thank you for your business!

LUG NUTS

CARS

CONICAL SPLINE DRIVE NUTS, BOLTS & KEYS

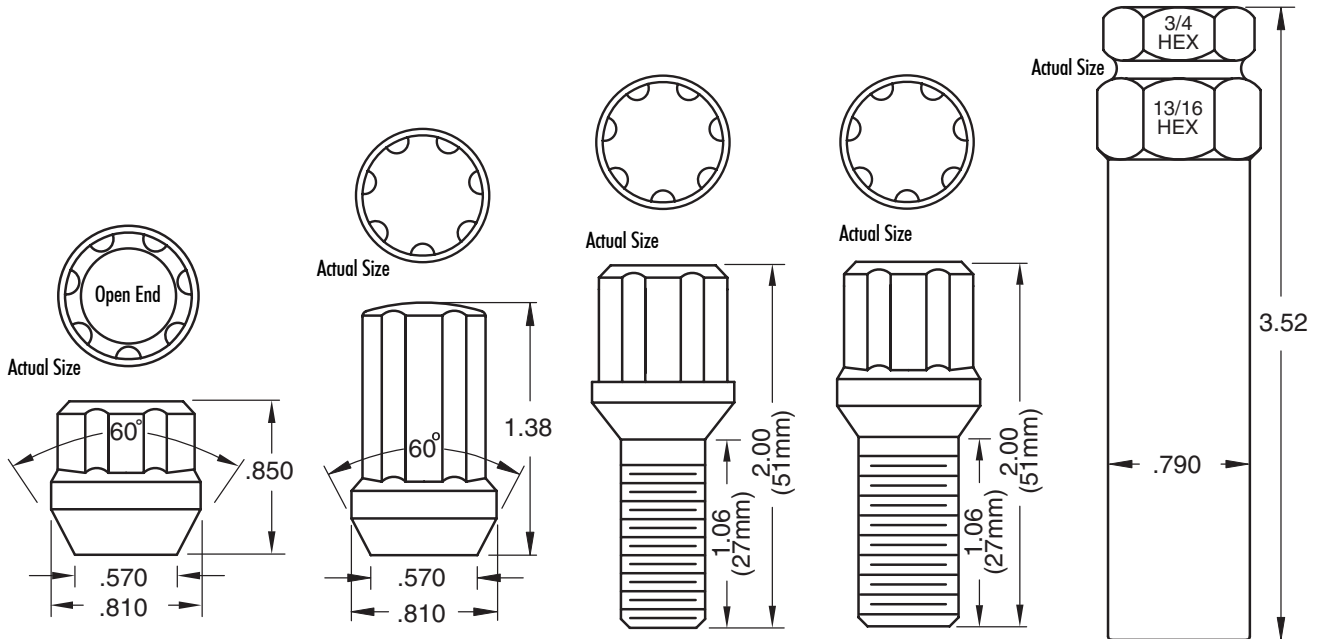

SIZE	PART#	SIZE	PART#	SIZE	PART#	SIZE	PART#	DESCRIPTION	PART#
1/2"	RH 5660	7/16"	RH 5652	12mm 1.50	RH 24-1227-C	14mm 1.50	RH 24-1427-C	SPLINE SOCKET KEY*	5699-SK
12mm 1.25	RH 5667	1/2"	RH 5650						
12mm 1.50	RH 5665	12mm 1.25	RH 5657						
		12mm 1.50	RH 5655						

.39^c
each

.49^c
each

.99^c
each

.99^c
each

\$1.19
each

*Not for use with impact wrench

TRUCKS

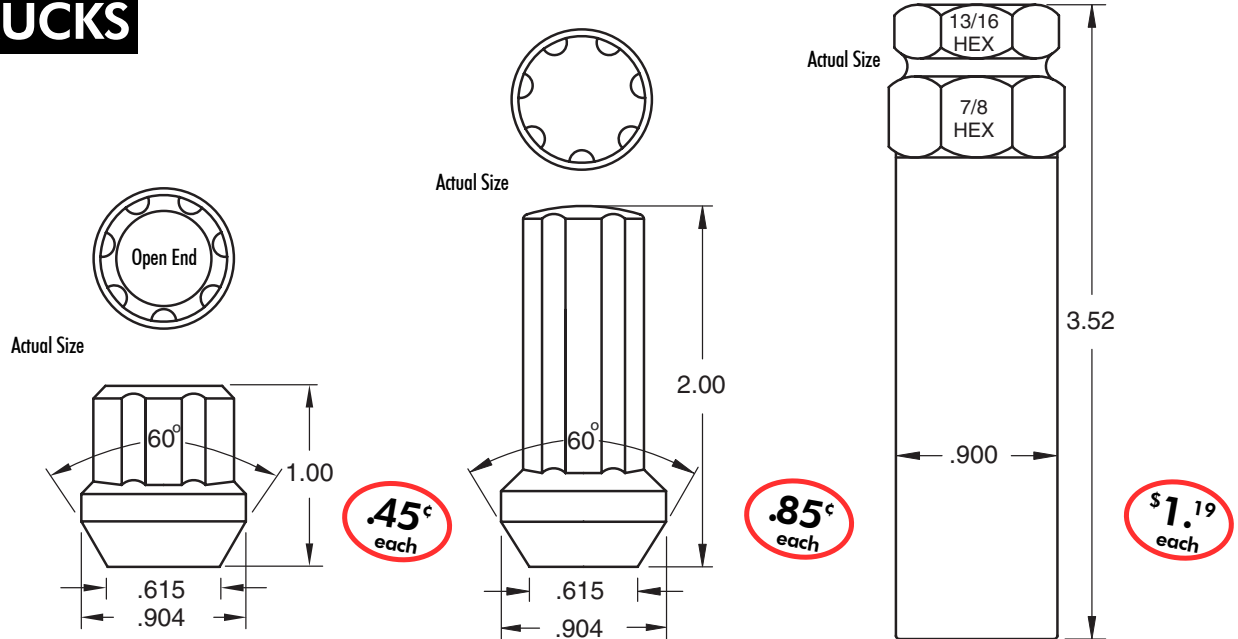

SIZE	PART#
9/16"	RH 5678
14mm 1.50	RH 5674
14mm 2.00	RH 5676

SIZE	PART#
9/16"	RH 5658
14mm 1.50	RH 5654
14mm 2.0	RH 5666

DESCRIPTION	PART#
SPLINE SOCKET KEY*	5699-SKT

.45^c
each

.85^c
each

\$1.19
each

*Not for use with impact wrench

NEW

LUG NUTS

SocketLugs™**CARS**

Accepts 3/8" socket extension

Actual Size

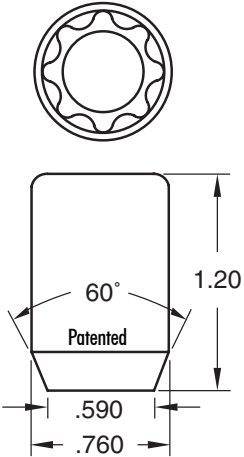
**.58^c**
each

Actual Size

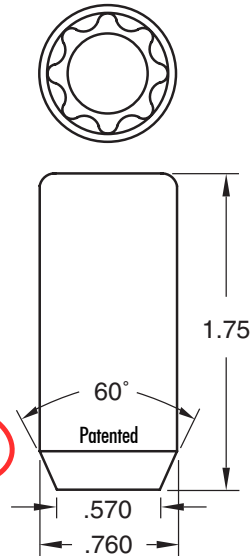
**.69^c**
each

Actual Size

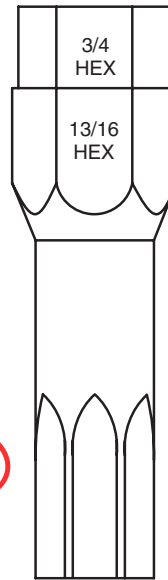
**\$1.49**
each

The SocketLug™ is an exciting and revolutionary idea.

Our patented design of the SocketLug™ has a pattern allowing the application of a standard four point socket extension.

8 points are better than 6!

SIZE		PART#
1/2"	RH	7800
12mm 1.25	RH	7807
12mm 1.50	RH	7805

SIZE		PART#
12mm 1.50	RH	7805XL

DESCRIPTION	PART#
SOCKET ADAPTER*	7899K

*Not for use with impact wrench

TRUCKS

Accepts 1/2" socket extension

Actual Size

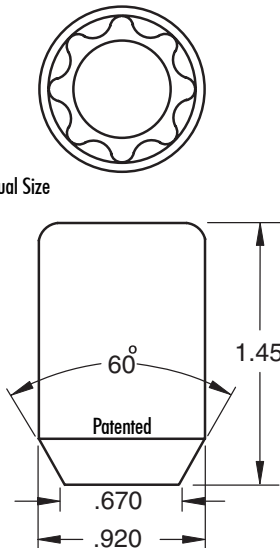
**.65^c**
each

Actual Size

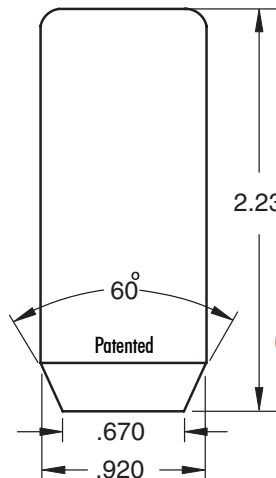
**.95^c**
each

Actual Size

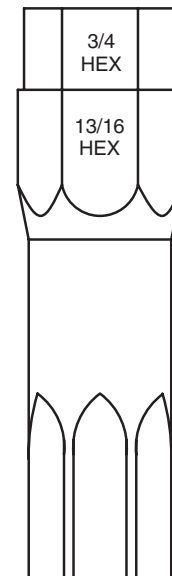
**\$1.49**
each

SIZE		PART#
9/16"	RH	7958
14mm 1.50	RH	7954

SIZE		PART#
9/16"	RH	7958XL
14mm 1.50	RH	7954XL
14mm 2.00	RH	7956XL

DESCRIPTION	PART#
SOCKET ADAPTER*	7999K

*Not for use with impact wrench

LUG NUTS

CARS

CONICAL TUNER NUTS & KEYS

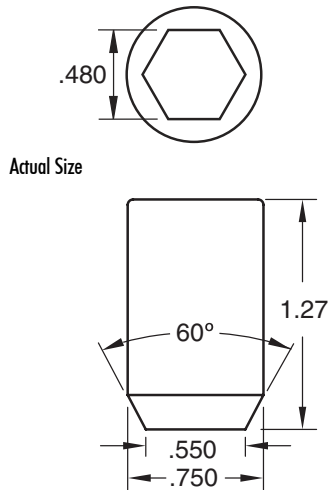

.48^c
each
Boxes of 100

SIZE		PART#
7/16"	RH	5642
1/2"	RH	5640
12mm 1.25	RH	5647
12mm 1.50	RH	5645
12mm 1.75	RH	5649

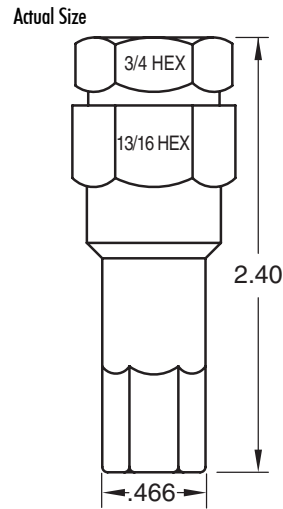

.99^c
each
Boxes of 20

DESCRIPTION	PART#
For use with 3/4 or 13/16 Hex Socket *	TK 2191

*Not for use with impact wrench

TRUCKS

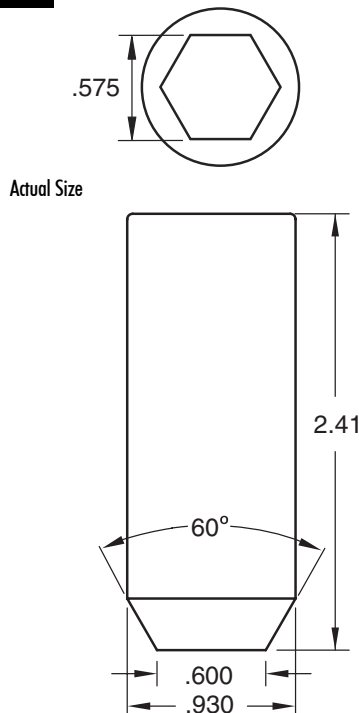

.85^c
each
Boxes of 50

SIZE		PART#
9/16"	RH	5648
14mm 1.50	RH	5644
14mm 2.00	RH	5646

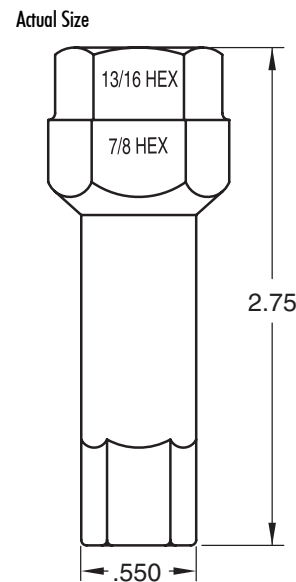

.99^c
each

DESCRIPTION	PART#
For use with 13/16 or 7/8 Hex Socket *	TK 670

*Not for use with impact wrench

LUG NUTS

CONICAL SEAT NUTS

O.E. 60 Degree Nuts, Cadmium Plated, Open End

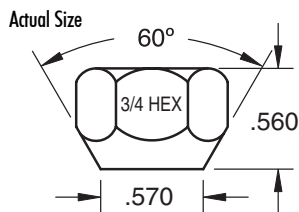

Boxes of 100

3/4" - 19mm Hex

SIZE		PART#
7/16"	RH	4502
1/2"	RH	4500
12mm 1.50	RH	4505

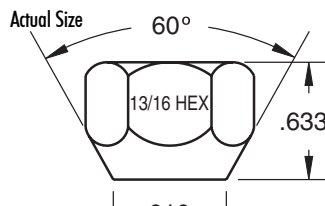
.20^c
each

Boxes of 100

13/16" - 21mm Hex

SIZE		PART#
1/2"	RH	4600
12mm 1.25	RH	4607
12mm 1.50	RH	4605
14mm 1.50	RH	4604
14mm 2.00	RH	4616

.20^c
each

Open End Conical Seat Bulge Nuts Cadmium Plated

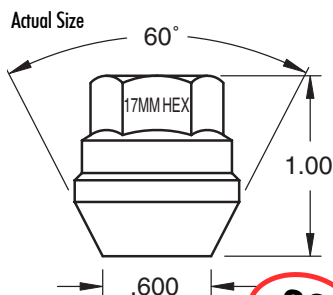

Boxes of 100

Cadmium Plated/Open End
17mm Hex

SIZE		PART#
1/2"	RH	5500
12mm 1.25	RH	5507
12mm 1.50	RH	5505

Finish and design varies.

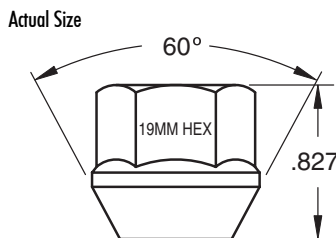
.29^c
each

Boxes of 100

Cadmium Plated/Open End
3/4" - 19mm Hex

SIZE		PART#
7/16"	RH	5552
1/2"	RH	5550
12mm 1.25	RH	5557
12mm 1.50	RH	5555
12mm 1.75	RH	5559
14mm 1.50	RH	5554
14mm 2.00	RH	5556

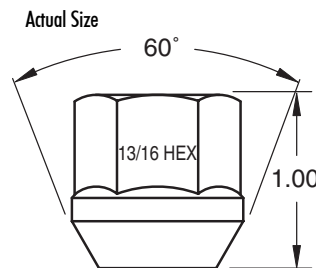
21mm hex version is available
by special order only..24^c
each

Boxes of 100

Cadmium Plated/Open End
13/16" - 21mm Hex

SIZE		PART#
9/16"	RH	5578
14mm 1.50	RH	5574
12mm 2.00	RH	5576

.29^c
eachOrders less than \$50.00 are subject to a \$10.00 small order fee.
Special large quantity pricing available on request.

CONICAL SEAT NUTS

Conical Seat Bulge Nuts

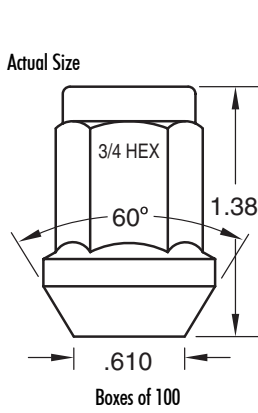

Chromed/Closed End
3/4" - 19mm Hex

SIZE		PART#
7/16"	RH	5452
1/2"	RH	5450
12mm 1.25	RH	5457
12mm 1.50	RH	5455
12mm 1.75	RH	5459
14mm 1.50	RH	5454

.29^c
each

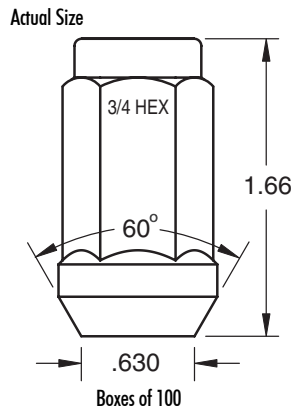

Chromed/Closed End
3/4" Hex

SIZE		PART#
14mm 1.50	RH	5454L

.49^c
each

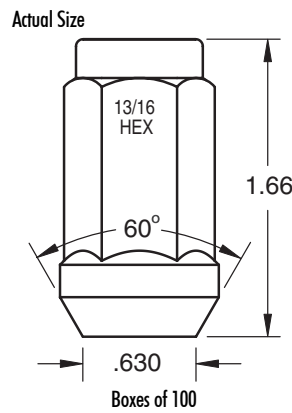

Chromed/Closed End
13/16" - 21mm Hex

SIZE		PART#
14mm 2.00	RH	5786

.49^c
each

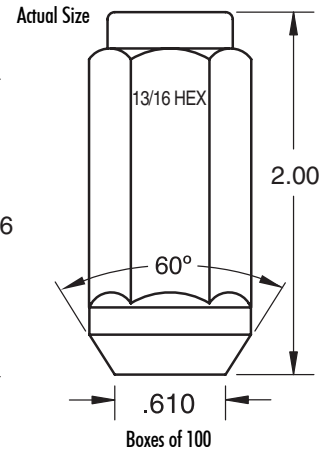

Chromed/Closed End
13/16" - 21mm Hex

SIZE		PART#
14mm 1.50	RH	5784L
14mm 2.00	RH	5786L

.49^c
each

Chrome Flat Top Conical Seat Nuts 1 piece

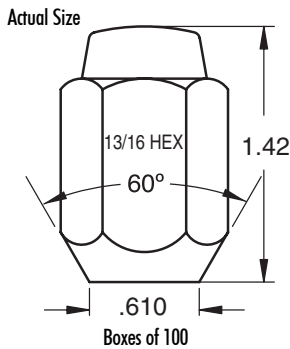

13/16" Hex

SIZE		PART#
7/16"	RH	5302
1/2"	RH	5300
12mm 1.25	RH	5307
12mm 1.50	RH	5305

.29^c
each

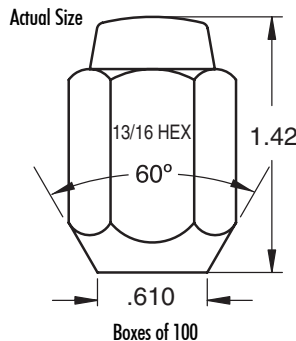

Special Application

SIZE		PART#
3/8"	RH	5324
10mm 1.25	RH	5328

.49^c
each

2 piece

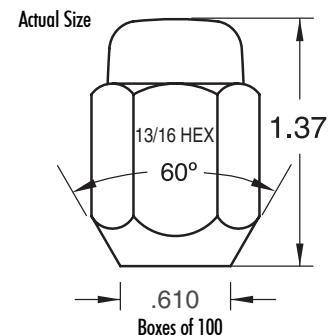

13/16" Hex

SIZE		PART#
7/16"	RH	5402
7/16"	LH	5403
1/2"	RH	5400
1/2"	LH	5401
12mm 1.25	RH	5407
12mm 1.50	RH	5405
12mm 1.50	LH	5406

.25^c
each

LUG NUTS

CONICAL SEAT DUPLEX NUTS

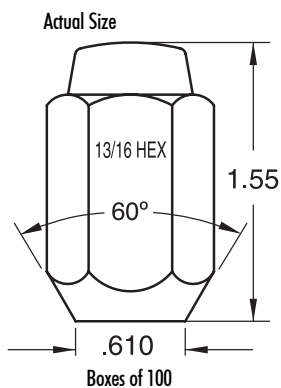

.54^c
each

Chromed
13/16" Hex

SIZE		PART#
9/16"	RH	5258
12mm 1.75	RH	5269
14mm 1.50	RH	5264S

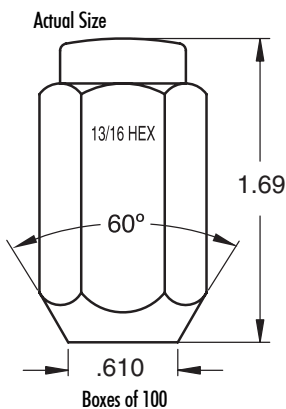

.54^c
each

Chromed
13/16" Hex

SIZE		PART#
14mm 1.50	RH	5264

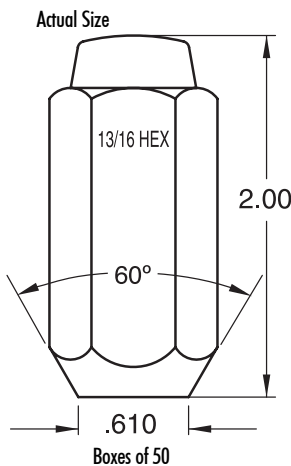

.69^c
each

Chromed
13/16" Hex

SIZE		PART#
14mm 1.50	RH	5244

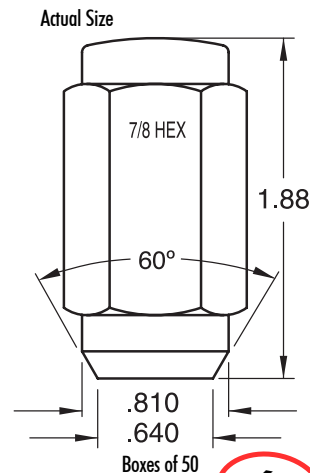

.65^c
each

Chromed
7/8" Hex

SIZE		PART#
1/2"	RH	5250L
9/16"	RH	5258L
14mm 1.50	RH	5264L
14mm 2.00	RH	5256L
5/8"	RH	5260L

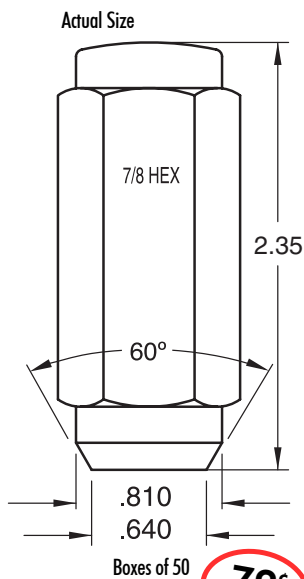

.79^c
each

Extra Long/
Chromed 7/8" Hex

SIZE		PART#
9/16"	RH	5258XL
14mm 2.00	RH	5256XL
14mm 1.50	RH	5264XL
5/8"	RH	5260XL

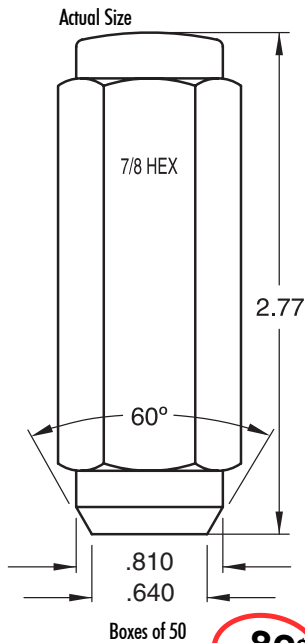

.89^c
each

Extra-Extra Long/
Chromed 7/8" Hex

SIZE		PART#
9/16"	RH	5258XXL

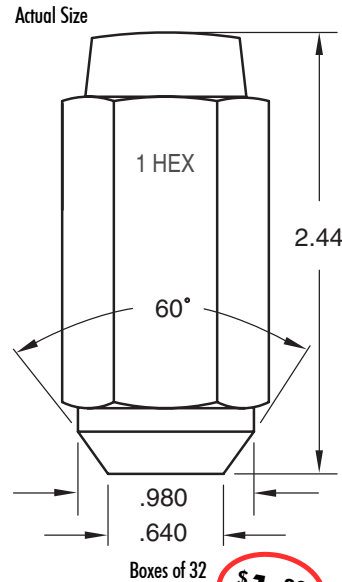

\$1.29
each

Extra Long/
Chromed 7/8" Hex

SIZE		PART#
5/8"	RH	5260XXL

CONICAL SEAT SHORT SHANK NUTS/ET

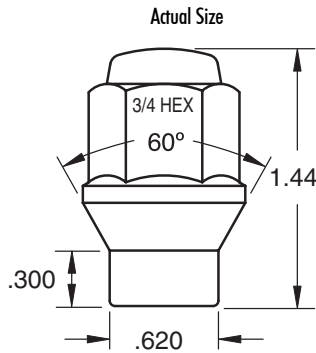

**Bulge Style/Chromed
3/4" Hex**

SIZE	PART#
7/16" RH	5392
1/2" RH	5390
12mm 1.25 RH	5397
12mm 1.50 RH	5395
12mm 1.75 RH	5399

Boxes of 100

**.48^c
each**

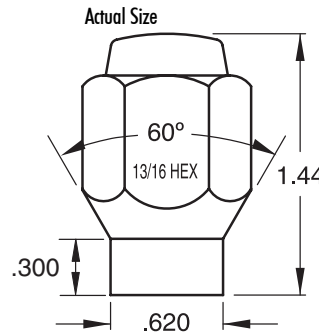

**Standard/Chromed
13/16" Hex**

SIZE	PART#
7/16" RH	5192
1/2" RH	5190
10mm 1.25 RH	5198
12mm 1.25 RH	5197
12mm 1.50 RH	5195

Boxes of 100

**.39^c
each**

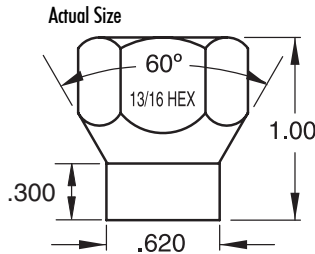

**Open End/Chromed
13/16" Hex**

SIZE	PART#
7/16" RH	5192-0
1/2" RH	5190-0
12mm 1.25 RH	5197-0
12mm 1.50 RH	5195-0
12mm 1.75 RH	5199-0

Boxes of 100

**.37^c
each**

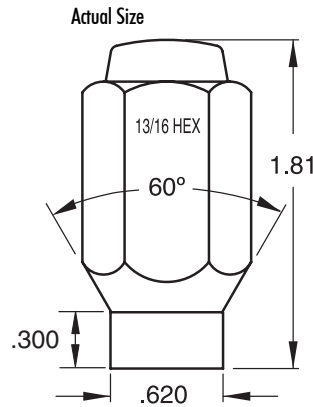

**Long/Chromed
13/16" Hex**

SIZE	PART#
1/2" RH	5190L
12mm 1.25 RH	5197L
12mm 1.50 RH	5195L
12mm 1.75 RH	5199L

Boxes of 100

**.54^c
each**

TRUCK

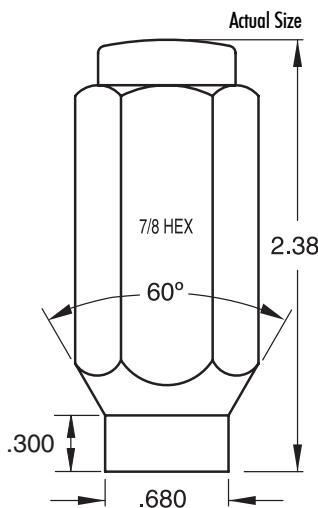

**Extra Long/Chromed
7/8" Hex**

SIZE	PART#
1/2" RH	5280XL
9/16" RH	5298XL
14mm 1.5 RH	5284XL
14mm 2.0 RH	5286XL

Boxes of 100

**.99^c
each**

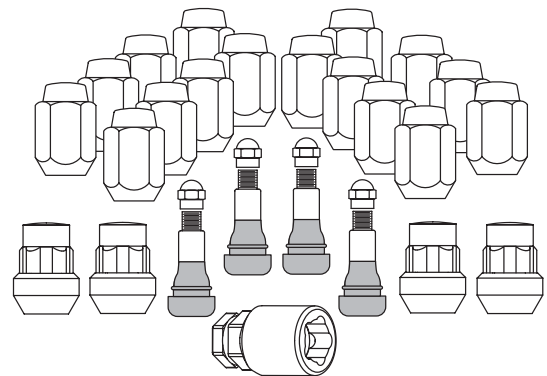

Wheel Installation Kits Available

4, 5, 6 & 8 Lug Applications

Packaged for your convenience

Call for Details

LUG NUTS

DUALEE CONICAL NUTS

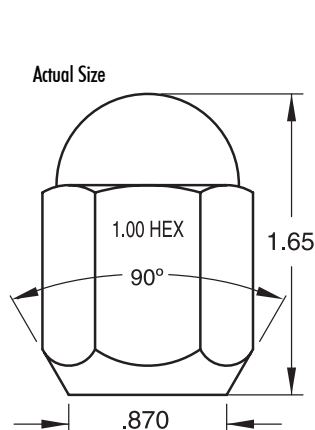

Short/Chromed
1" Hex

SIZE		PART#
9/16"	RH	5288S
14mm 1.50	RH	5294S

\$1.29
each

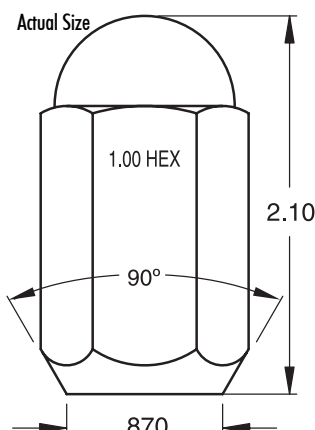

Standard/Chromed
1" Hex

SIZE		PART#
9/16"	RH	5288

\$1.29
each

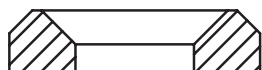

Recommended washer
#5498C (refer to washer
section for details)

.99¢
each

Boxes of 32, washer not included.

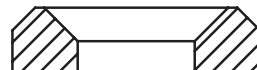

Recommended washer
#5498C (refer to washer
section for details)

.99¢
each

Boxes of 32, washer not included

AFTERMARKET DUALEE NUTS

Used on these wheels:
American Eagle • KMC • Prime • Progressive and others

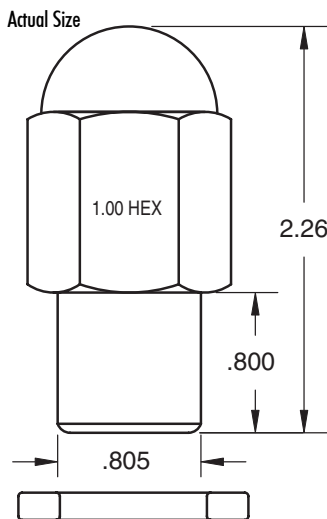

Boxes of 32, washer not included

.800" SHANK

uses 5484C washer See page #27

SIZE		PART#
9/16"	RH	5098-P
5/8"	RH	5090-P
14mm 1.50	RH	5094-P
14mm 2.0	RH	5096-P

\$2.99
each

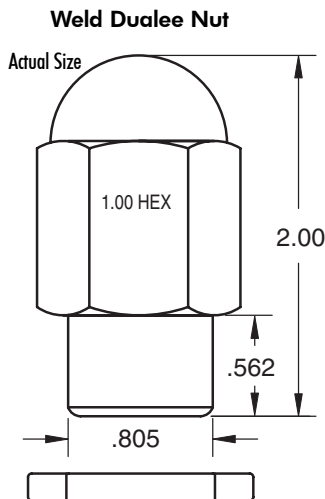

Boxes of 32, washer not included

.550" SHANK

uses 5484C washer See page #27

SIZE		PART#
9/16"	RH	5088-WS
5/8"	RH	5090-WS
14mm 1.50	RH	5094-WS

\$2.99
each

Weld Super Single Nut

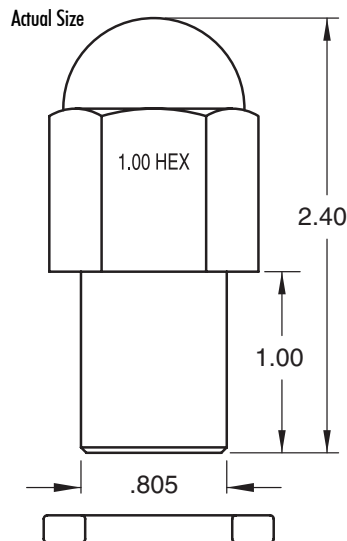

Boxes of 32, washer not included

1" SHANK

uses 5484C washer See page #27

SIZE		PART#
1/2"	RH	5080-W
9/16"	RH	5098-W
5/8"	RH	5090-W
14mm 1.50	RH	5094-W

\$2.99
each

Orders less than \$50.00 are subject to a \$10.00 small order fee. Special large quantity pricing available on request.

MAG STYLE NUTS

(2 piece)

Chromed/Standard
13/16" Hex

SIZE		PART#
7/16"	RH	5202
7/16"	LH	5203
1/2"	RH	5200
1/2"	LH	5201
12mm 1.25	RH	5207
12mm 1.50	RH	5205
12mm 1.50	LH	5206

Recommended washers:
5481 See page #27
#5485-C (chrome)

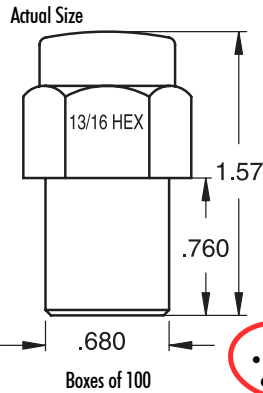

(2 piece)

Flat Top Short Shank
Chromed/Closed End
13/16" Hex

SIZE		PART#
7/16"	RH	5172
1/2"	RH	5170
12mm 1.50	RH	5175
12mm 1.25	RH	5177

Recommended washers:
5481 See page #27
#5485-C (chrome)

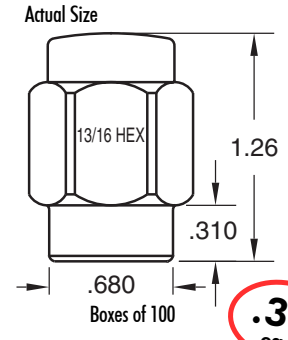

ONE PIECE MAG STYLE NUTS

Actual Size

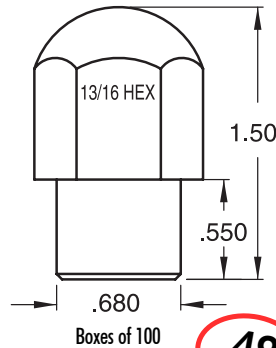

Short/Chromed
13/16" Hex

SIZE		PART#
7/16"	RH	5102
1/2"	RH	5100
12mm 1.25	RH	5107
12mm 1.50	RH	5105

Recommended # 5481 See page #27
washers: #5485-C (chrome)

Actual Size

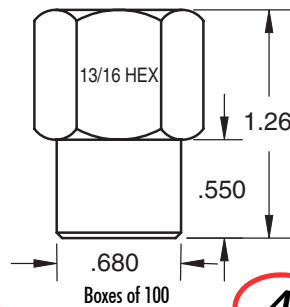

Open End/Chromed
13/16" Hex

SIZE		PART#
7/16"	RH	5102-0
1/2"	RH	5100-0
12mm 1.50	RH	5105-0

Recommended # 5481 See page #27
washers: #5485-C (chrome)

Actual Size

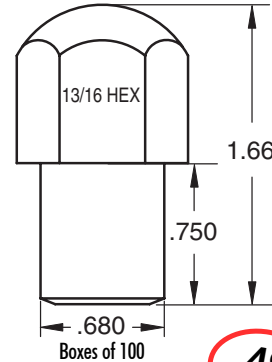

Medium/Chromed
13/16" Hex

SIZE		PART#
12mm 1.50	RH	5005

Recommended # 5481 See page #27
washers: #5485-C (chrome)

Actual Size

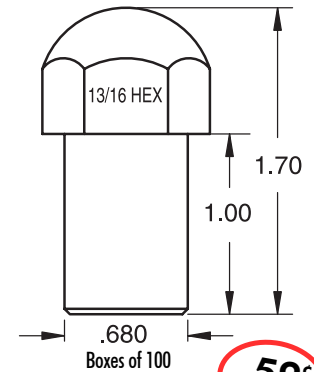

Long/Chromed
13/16" Hex

SIZE		PART#
7/16"	RH	5112
1/2"	RH	5110
12mm 1.25	RH	5117
12mm 1.50	RH	5115

Recommended # 5481 See page #27
washers: #5485-C (chrome)

SST STYLE EXTRA LONG MAG NUTS

(2 piece)

Chromed/Closed End
13/16" Hex

SIZE		PART#
7/16"	RH	5122
1/2"	RH	5120
12mm 1.25	RH	5127
12mm 1.50	RH	5125

Recommended washer
#5486 (chrome) See page #27

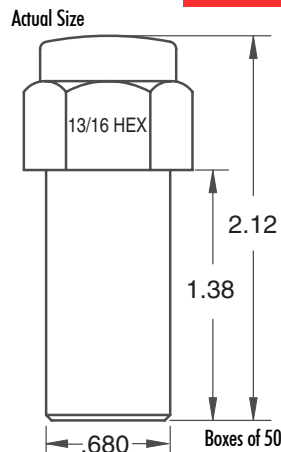

(1 piece)

Chromed/Open End
13/16" Hex

SIZE		PART#
7/16"	RH	5122-0
1/2"	RH	5120-0
12mm 1.50	RH	5125-0

Recommended washer
#5486 (chrome) See page #27

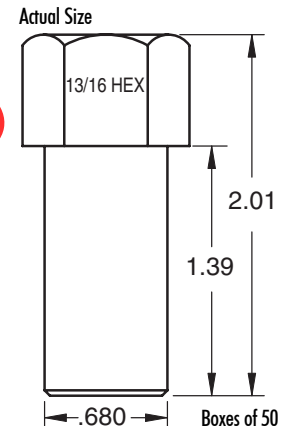

LUG NUTS

MAG SEAT DUPLEX NUTS

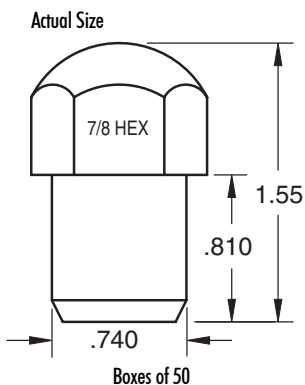

**Short/Chromed
7/8" Hex**

SIZE	PART#
------	-------

14mm 1.50 RH* 5084S

*Formerly Part #5074

Recommended washer #5482 See page #27

**\$.69^c
each**

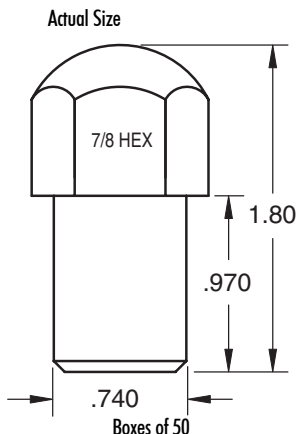

**Standard/Chromed
7/8" Hex**

SIZE	PART#
------	-------

1/2" RH 5080

9/16" RH 5088

14mm 1.50 RH* 5084

*Formerly Part #5074L

Recommended washer #5482 See page #27

**\$.69^c
each**

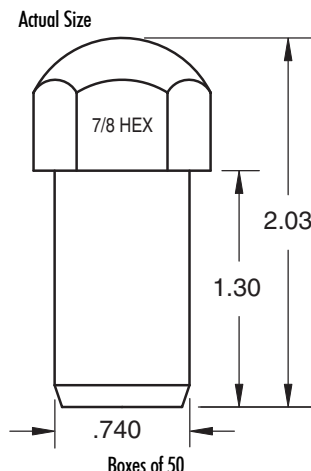

**Extra Long/Chromed
7/8" Hex**

SIZE	PART#
------	-------

1/2" RH 5080 XL

Recommended washer #5482 See page #27

**\$1.10^c
each**

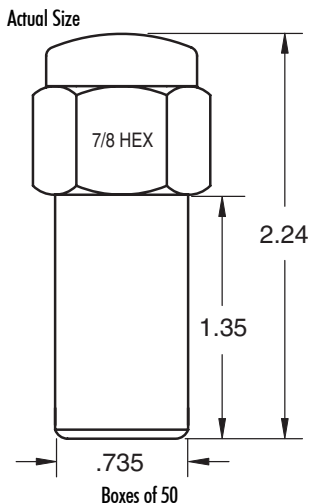

**Extra Long/Chromed
7/8" Hex**

SIZE	PART#
------	-------

14mm 1.50 RH* 5084 XL

*Formerly Part #5074XL

Recommended washer #5482 See page #27

**\$1.10^c
each**

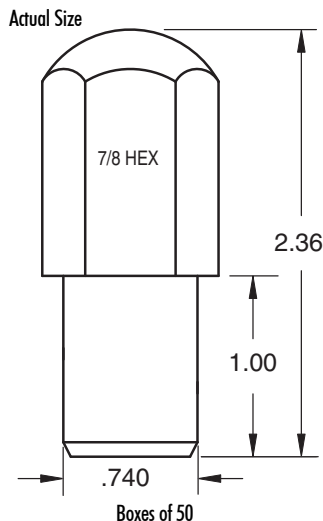

**Extra Long/Chromed
7/8" Hex**

SIZE	PART#
------	-------

9/16" RH 5088 XL

Recommended washer #5482 See page #27

**\$1.49^c
each**

LUG NUTS

SPECIAL APPLICATION LUG NUTS & ACCESSORIES

CIRCLE TRACK LUG NUTS

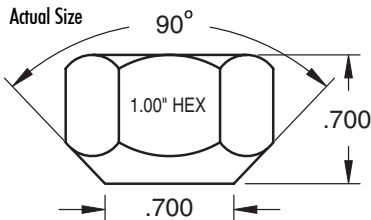

SIZE	PART#
5/8 x 18 RH	60-1530

.75¢
each

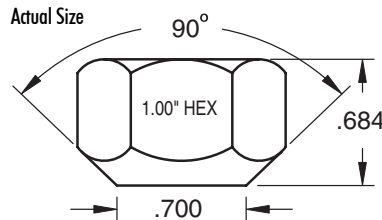

SIZE	PART#
5/8 x 11 RH	60-1531

.75¢
each

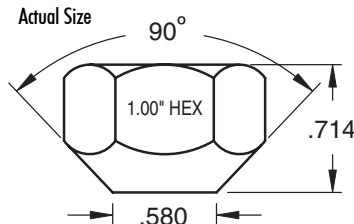

SIZE	PART#
7/16" x 20 RH	60-1502
1/2" x 20 RH	60-1504

.75¢
each

TOYOTA FACTORY ALLOY

Fits Toyota O.E. Car & Truck alloys that use "Mag Style" Lug nuts (supplied with attached chromed washer)

Actual Size

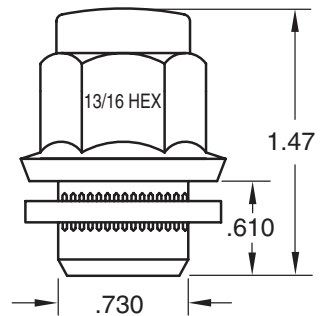

SIZE	PART#
12mm 1.50 RH	5077

Boxes of 100

\$1.10
each

OUTSIDE THREAD GM STYLE LUG NUTS

Accepts screw on decorative covers

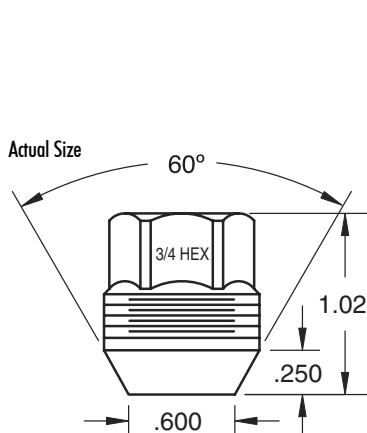

SIZE	PART#
7/16 RH	5802
12mm 1.5 RH	5855

Uses Part#99-9709-1 lug cover

See page #17

.75¢
each

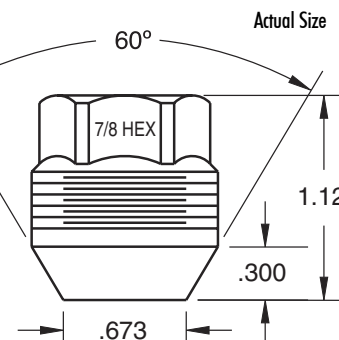
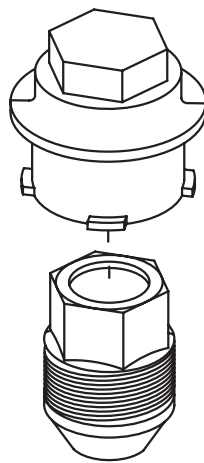

SIZE	PART#
1/2 RH	5900
7/16 RH	5902
9/16 RH	5958
14mm 1.5 RH	5954

Uses Part#99-9831 lug cover

See page #17

.75¢
each

Use these to dress up your Camaro, Corvette, GM Truck or SUV

NUT OR BOLT HEAD COVERS

17MM CHROME OR BLACK LUG BOLT COVERS

THOSE O.E. GUYS HAVE DONE IT TO US AGAIN!

Since 2000, the O.E. bolt supplier for both Mercedes Benz and BMW has changed their manufacturing process.

These new bolts now have a very slight concave on the side of the bolt where the lug wrench fits (see drawing). It is not truly flat.

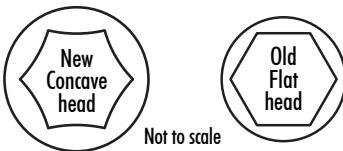

Not to scale

As a result, Lug Bolt Covers that formally fit fine, now can be a little loose and may come off.

This has caused us to design a NEW Lug cover.

THERE IS SOME GOOD NEWS!

Now we offer 2 different part numbers.

One for the new style concave O.E. bolts.

One for flat O.E. and all aftermarket bolts.

We have designed the parts in a way so it is easy for you to tell the difference.

Turn the bolt cover over and look at the inside (see drawings).

Designed to fit ALL 17MM hex heads

The one with 6 little tabs on the inside is for the traditional style flat side bolts.

Our part # 99-9713

Not to scale

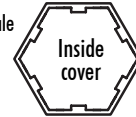

The one with 12 little tabs on the inside is for the new style concave side bolts.

Our part # 99-9712

Not to scale



17mm		17mm	
Not to scale	Not to scale	Not to scale	Not to scale
	12 TAB		6 TAB
Not to scale	Inside cover	Not to scale	Inside cover
Not to scale		Not to scale	
FINISH	PART#	FINISH	PART#
Chrome	99-9712-C	Chrome	99-9713-C
Black	99-9712-B	Black	99-9713-B
.69¢ each	Packaged in bags of 20 with removal tool	.69¢ each	Packaged in bags of 20 with removal tool
Bulk Pricing available for lots of 500 or more.			

Prestige
WHEEL ACCESSORIES

(800) 854-6770 (877) LUG-NUTS

(714) 841-6333

Fax: (714) 841-6413

5 8 4 - 6 8 8 7

M-F 7:30AM - 4:30PM CALIF TIME

NUT OR BOLT HEAD COVERS

19MM LUG BOLT COVERS

Chrome or black covers for use on lug bolts with 19mm hex head.

FINISH	PART#
Chrome	99-9999-C
Black	99-9999-B

.69¢
each



Packaged in bags of 20 with removal tool
Not to scale

CHEVY/GMC CHROME LUG COVERS

Replace the factory black covers with these chromed covers to give your custom wheels that finished off look.

For use on all larger O.D. GM outside threaded style lug nuts with 7/8" hex. (i.e. most truck applications)

FINISH	YEAR	PART#
Chrome	Thru '02	99-9831
Chrome	'03 on	99-9832*

.69¢
each

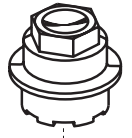

Not to scale

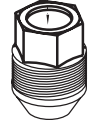

*Slightly longer version

EARLY CORVETTE CHROME LUG BOLT COVERS

This special application chrome plated lug cover was designed for use on all early Corvette's that have outside threaded style lug nuts.

FINISH	PART#
Chrome	99-9994

.99¢
each

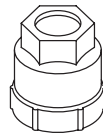

Not to scale



CAMARO/CORVETTE CHROME LUG COVERS

Replace the factory black covers with these chromed covers to give your custom wheels that finished off look.

For use on all smaller O.D. GM outside threaded style lug nuts with 3/4" hex. (i.e. most car applications)

FINISH	PART#
Chrome	99-9709-1

.69¢
each

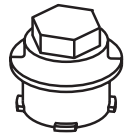

Not to scale

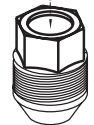

SMALL CHROME HEX HEAD COVERS

These universal nut covers can be used in the engine bay or interior area of your vehicle to dress up any exposed bolt heads.

Fits the following:

THREAD SIZE	HEX HEAD SIZE
6 mm	10 mm

FINISH	PART#
Chrome	PWA-NCC-0610

Per bag of 50
\$9.95
per bag

Packaged in bags of 50pcs.

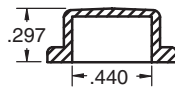
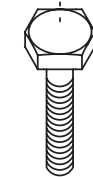

Not to scale

LARGE CHROME HEX HEAD COVERS

These universal nut covers can be used in the engine bay or interior area of your vehicle to dress up any exposed bolt heads.

Fits the following:

THREAD SIZE	HEX HEAD SIZE
8 mm	13 mm

FINISH	PART#
Chrome	PWA-NCC-0813

\$9.95
per bag

Packaged in bags of 50pcs.

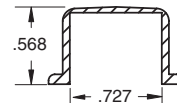
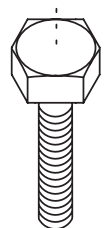
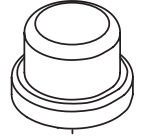

Not to scale

LUG BOLTS

IMPORTANT

Lug bolt applications are much more difficult than lug nuts. For example, there are varying lengths, seats and thread sizes to consider. If an incorrect bolt is used, a wheel may fall off, someone may be killed or injured and you and/or your company could be sued. All this because someone didn't take a few extra minutes to choose the correct bolt for a specific application.

IMPORTANT THINGS TO LOOK FOR:

The origin of the wheel is vitally important, be absolutely sure if the wheel is...

- 1) an O.E. factory alloy wheel.
- 2) an aftermarket reproduction of a factory wheel.
- 3) an aftermarket style wheel.

While most O.E. factory wheels that are made in Europe (Mercedes-Benz, Audi, VW and some Porsche) use ball seat bolts, there are some exceptions (BMW, Saab and others) that use conical (cone) seat bolts.

Reproductions and aftermarket wheels, depending on the company, vary greatly, so watch out! In fact, many wheel companies use both ball seat and conical seat lug bolts. Use the wrong style bolt seat, you will have major problems...guaranteed. If you are lucky and the wheel doesn't work loose and fall off, it will surely vibrate from incorrect seating.

It is impossible for Prestige Wheel Accessories to document all of the information about all of the many different wheel manufacturers and possible applications. It must therefore be the responsibility of you, the installer, to make the correct choice.

OUR POLICY ON BOLTS IS:

Prestige Wheel Accessories will make every effort to provide you with information so that you can make the correct selection. However, should the lug bolts you choose prove to be incorrect or not the ones you thought they were, Prestige is under no obligation to take them back. Should Prestige agree to accept the lug bolts back, it will be under the following conditions only:

- 1) the bolts must be new and unused merchandise in original resalable condition.
- 2) you must obtain an RTS (Return to Stock) number before shipping merchandise back to Prestige.
- 3) all freight back to Prestige must be prepaid.
- 4) a 20% restocking fee will be charged.
- 5) all credits or refunds will apply to merchandise only, no credit will be allowed for shipping costs.

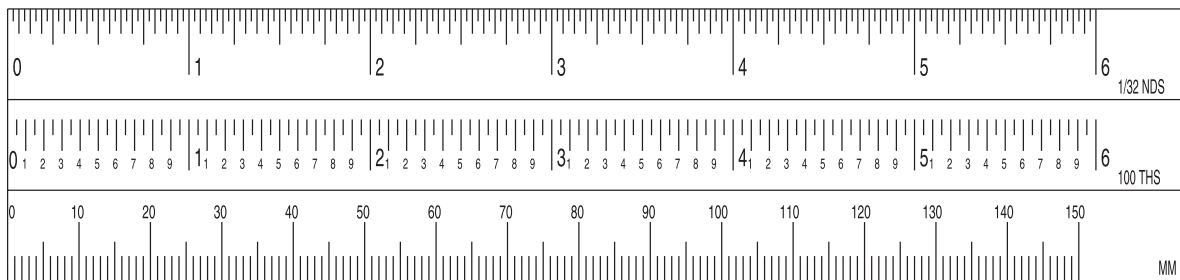

SPECIAL LUG BOLT ORDER FORM

Date ___/___/___

Company Name _____

Contact _____

Phone # _____

Please specify the vehicle information that the lug bolts will be used on:

Year _____

Make _____

Model _____

Original factory alloy wheels -or- Aftermarket alloy wheels

Ball seat

-or-

Conical seat

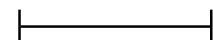
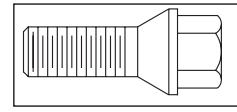
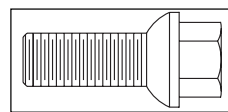

Overall length _____

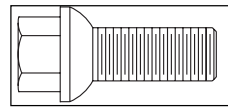

Shank length _____

Thread size:

12mm 1.50 12mm 1.75 14mm 1.50

Part # _____ Qty _____

Prestige
WHEEL ACCESSORIES

(800) 854-6770 (877) LUG-NUTS

(714) 841-6333

5 8 4 - 6 8 8 7

Fax: (714) 841-6413

M-F 7:30AM - 4:30PM CALIF TIME

LUG BOLTS

CONE SEAT LUG BOLTS

Dacromet Coated - *Dacromet coating is a dull silver finish that provides a high corrosion resistance (500 hr salt spray). As specified by Mercedes Benz factory.

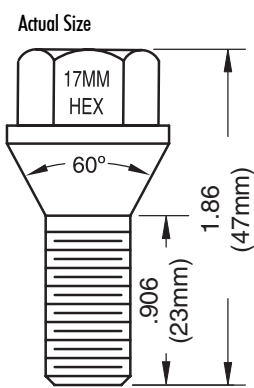

Dacromet
47mm - Overall
23mm - Shank

SIZE	PART#
12mm 1.50 RH	20-4040-C

Boxes of 20 **\$1.49 each**

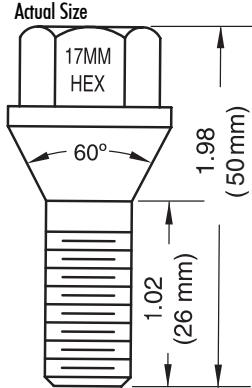

Dacromet
50mm - Overall
26mm - Shank

SIZE	PART#
12mm 1.50 RH	20-4065-C

Boxes of 20 **\$1.49 each**

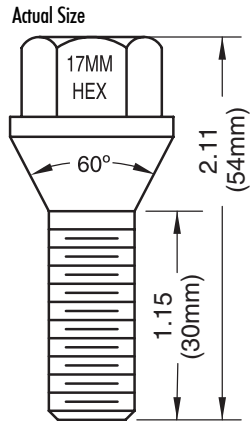

Dacromet
54mm - Overall
30mm - Shank

SIZE	PART#
12mm 1.50 RH	20-4095-C

Boxes of 20 **\$1.49 each**

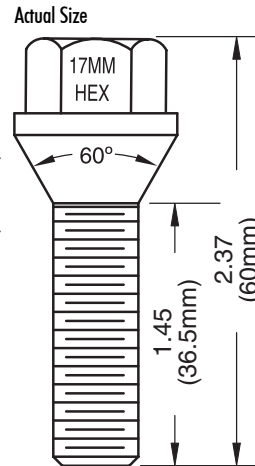

Dacromet
60mm - Overall
36.5mm - Shank

SIZE	PART#
12mm 1.50 RH	20-4136-C

Boxes of 20 **\$1.79 each**

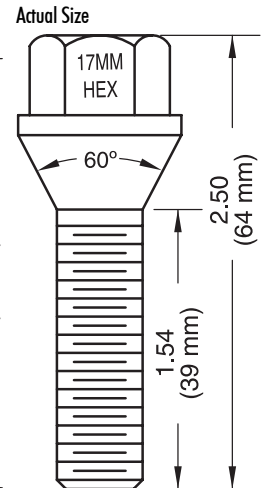

Dacromet
64mm - Overall
39mm - Shank

SIZE	PART#
12mm 1.50 RH	20-4138-C

Boxes of 20 **\$1.79 each**

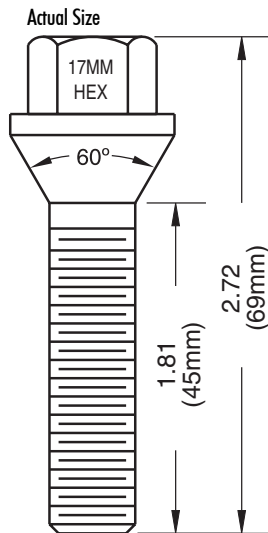

Dacromet
69mm - Overall
45mm - Shank

SIZE	PART#
12mm 1.50 RH	20-4162-C

Boxes of 20 **\$1.79 each**

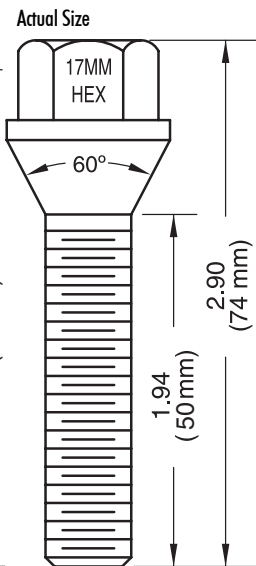

Dacromet
74mm - Overall
50mm - Shank

SIZE	PART#
12mm 1.50 RH	20-4170-C

Boxes of 20 **\$2.79 each**

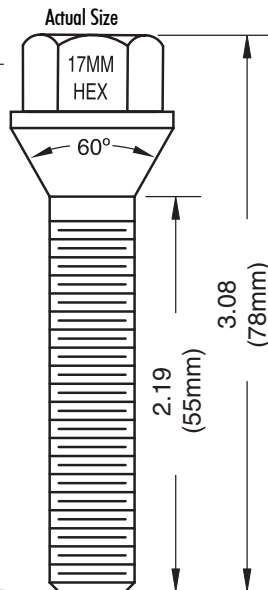

Dacromet
78mm - Overall
55mm - Shank

SIZE	PART#
12mm 1.50 RH	20-4179-C

Boxes of 20 **\$2.79 each**

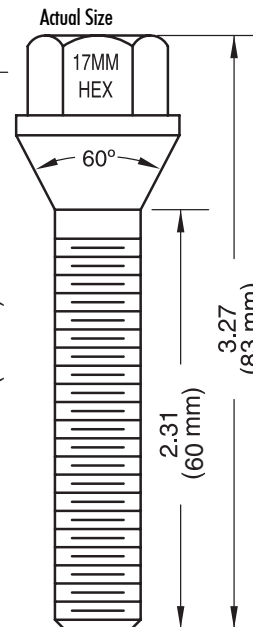

Dacromet
83mm - Overall
60mm - Shank

SIZE	PART#
12mm 1.50 RH	20-4180-C

Boxes of 20 **\$2.79 each**

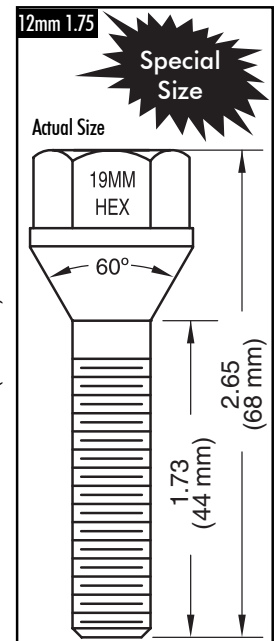

Dacromet
68mm - Overall
44mm - Shank

SIZE	PART#
12mm 1.75 RH	20-4164-C

Boxes of 20 **\$2.79 each**

Other lengths available upon special request

LUG BOLTS

CONE SEAT LUG BOLTS

Dacromet Coated - 14mm

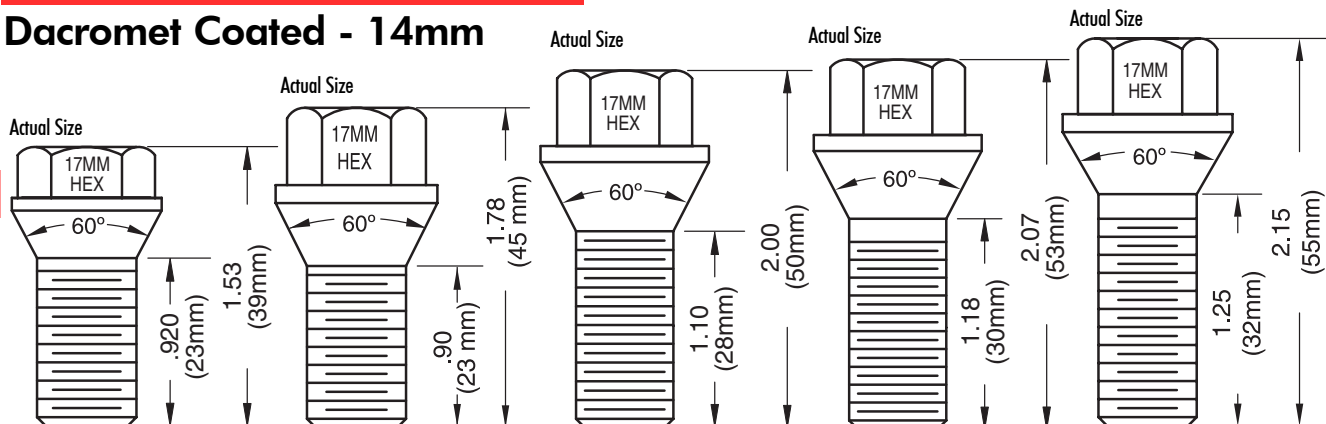

Dacromet
39mm - Overall
23mm - Shank

Dacromet
45mm - Overall
23mm - Shank

Dacromet
50mm - Overall
28mm - Shank

Dacromet
53mm - Overall
30mm - Shank

Dacromet
55mm - Overall
32mm - Shank

SIZE	PART#
14mm 1.50 RH	20-4211-C

SIZE	PART#
14mm 1.50 RH	20-4212-C

SIZE	PART#
14mm 1.50 RH	20-4240-C

SIZE	PART#
14mm 1.50 RH	20-4259-C

SIZE	PART#
14mm 1.50 RH	20-4263-C

Boxes of 20 **\$1.49** each

Boxes of 20 **\$1.49** each

Boxes of 20 **\$1.59** each

Boxes of 20 **\$1.89** each

Boxes of 20 **\$1.89** each

* Dacromet coating is a dull silver finish that provides a high corrosion resistance (500 hr salt spray). As specified by Mercedes Benz factory.

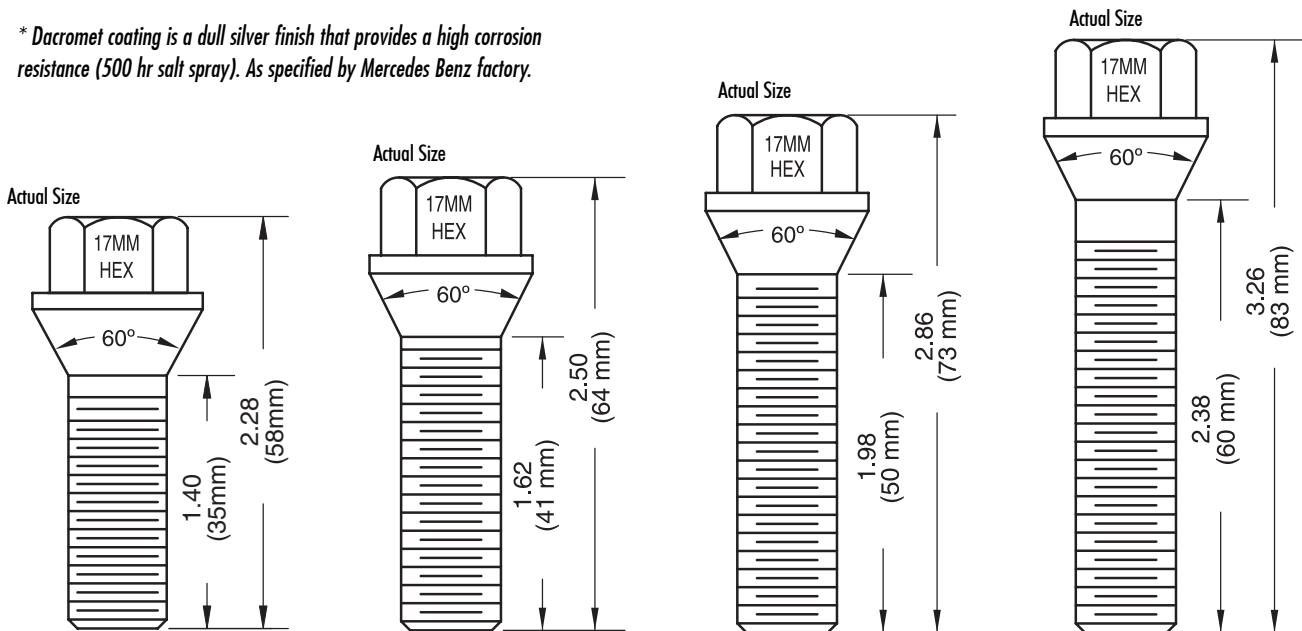

Dacromet
58mm - Overall
35mm - Shank

Dacromet
64mm - Overall
41mm - Shank

Dacromet
73mm - Overall
50mm - Shank

Dacromet
83mm - Overall
60mm - Shank

SIZE	PART#
14mm 1.50 RH	20-4271-C

SIZE	PART#
14mm 1.50 RH	20-4290-C

SIZE	PART#
14mm 1.50 RH	20-4309-C

SIZE	PART#
14mm 1.50 RH	20-4316-C

Boxes of 20 **\$1.89** each

Boxes of 20 **\$2.79** each

Boxes of 20 **\$2.79** each

Boxes of 20 **\$2.99** each

Orders less than \$50.00 are subject to a \$10.00 small order fee. Special large quantity pricing available on request.

LUG BOLTS

CONE SEAT LUG BOLTS

Chrome Plated - 12mm

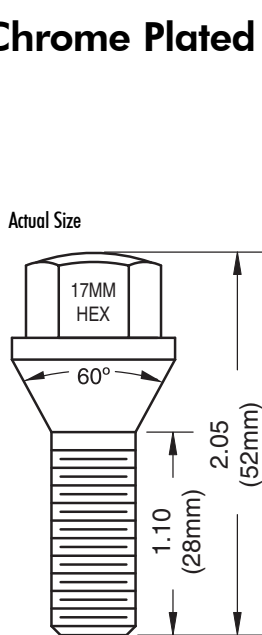

Chrome
52mm - Overall
28mm - Shank

SIZE	PART#
12mm 1.50 RH	*19-12528-C

*Formerly Part#99-2152

Boxes of 20

.99¢
each

Quantity of 100

.69¢
each

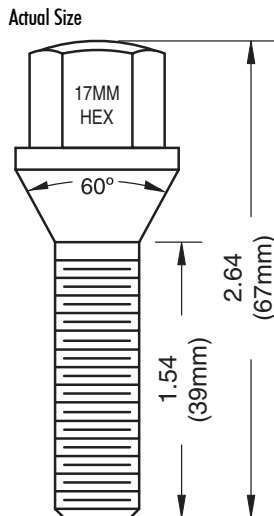

Chrome
67mm - Overall
39mm - Shank

SIZE	PART#
12mm 1.50 RH	19-12539-C

Boxes of 20

\$1.39
each

Quantity of 100

.99¢
each

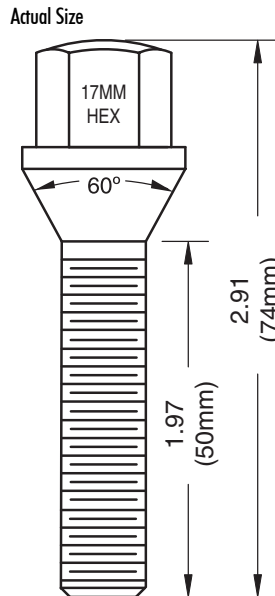

Chrome
74mm - Overall
50mm - Shank

SIZE	PART#
12mm 1.50 RH	19-12550-C

Boxes of 20

\$1.69
each

Quantity of 100

\$1.19
each

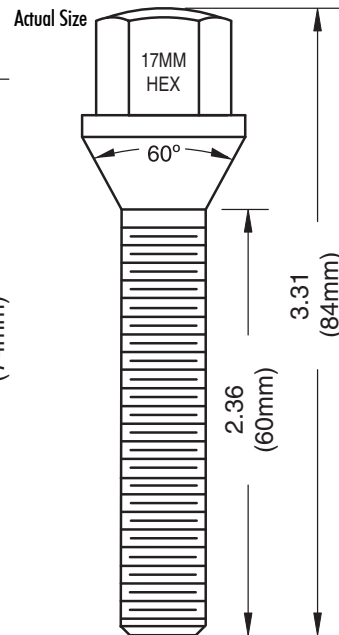

Chrome
84mm - Overall
60mm - Shank

SIZE	PART#
12mm 1.50 RH	19-12560-C

Boxes of 20

\$1.99
each

Quantity of 100

\$1.39
each

Chrome Plated - 14mm

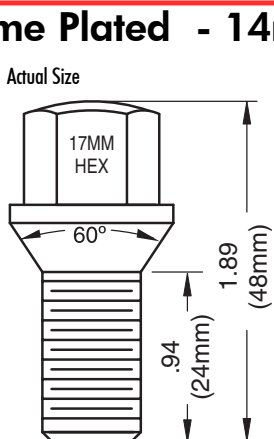

Chrome
48mm - Overall
24mm - Shank

SIZE	PART#
14mm 1.50 RH	19-14524-C

Boxes of 20

.99¢
each

Quantity of 100

.69¢
each

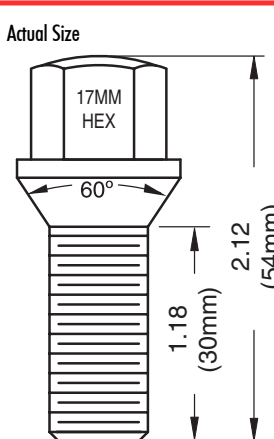

Chrome
54mm - Overall
30mm - Shank

SIZE	PART#
14mm 1.50 RH	*19-14530-C

*Formerly Part#99-2154

Boxes of 20

\$1.29
each

Quantity of 100

.89¢
each

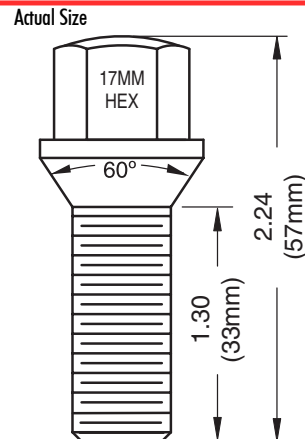

Chrome
57mm - Overall
33mm - Shank

SIZE	PART#
14mm 1.50 RH	19-14533-C

Boxes of 20

\$1.39
each

Quantity of 100

.99¢
each

LUG BOLTS

BALL SEAT LUG BOLTS

Dacromet Coated - 12mm

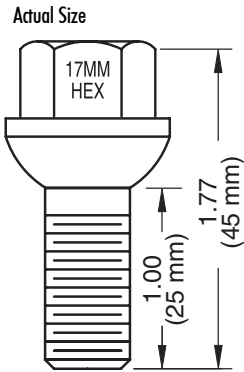

Dacromet
45mm - Overall
25mm - Shank

SIZE	PART#
12mm 1.50 RH	20-4053-B

Boxes of 20 **\$1.59** each

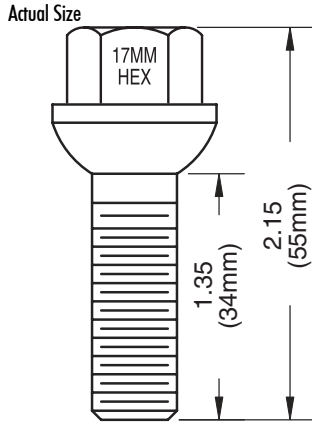

Dacromet
55mm - Overall
34mm - Shank

SIZE	PART#
12mm 1.50 RH	20-4122-B

Boxes of 20 **\$1.59** each

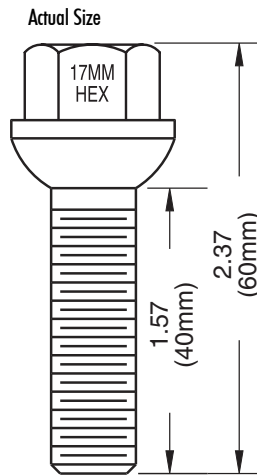

Dacromet
60mm - Overall
40mm - Shank

SIZE	PART#
12mm 1.50 RH	20-4146-B

Boxes of 20 **\$1.89** each

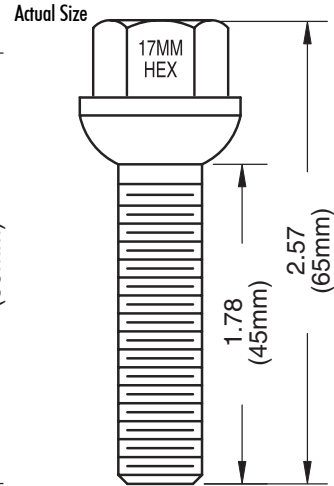

Dacromet
65mm - Overall
45mm - Shank

SIZE	PART#
12mm 1.50 RH	20-4163-B

Boxes of 20 **\$2.79** each

* Dacromet coating is a dull silver finish that provides a high corrosion resistance (500 hr salt spray). As specified by Mercedes Benz factory.

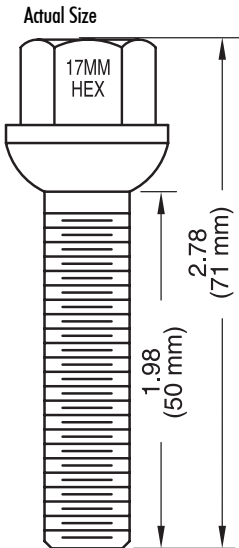

Dacromet
71mm - Overall
50mm - Shank

SIZE	PART#
12mm 1.50 RH	20-4169-B

Boxes of 20 **\$2.79** each

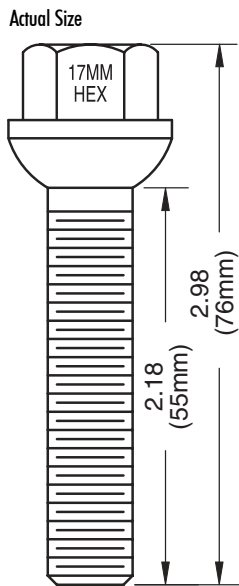

Dacromet
76mm - Overall
55mm - Shank

SIZE	PART#
12mm 1.50 RH	20-4176-B

Boxes of 20 **\$2.79** each

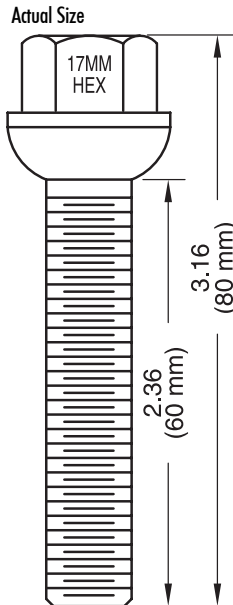

Dacromet
80mm - Overall
60mm - Shank

SIZE	PART#
12mm 1.50 RH	20-4183-B

Boxes of 20 **\$2.99** each

LUG BOLT COVERS BLACK OR CHROME

These covers give your lug bolts that finished look.

Available in both chrome or black

Available to fit either 17mm or 19mm hex head lug bolts or nuts.

Packaged in sets of 20 with removal tool.



Not to scale

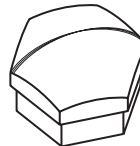

.69^c
each

FINISH	SIZE	PART#
Chrome	17mm	99-9712-C
Black	17mm	99-9712-B
Chrome	17mm	99-9713-C
Black	17mm	99-9713-B
Chrome	19mm	99-9999-C
Black	19mm	99-9999-B

Packaged in sets of 20 in a poly bag w/header card.
Bulk Pricing: Lots of 500 or more available upon request.

Also see page #84 for Mercedes-Benz lug bolt application sizes.

LUG BOLTS

BALL SEAT LUG BOLTS

Dacromet Coated - 14mm

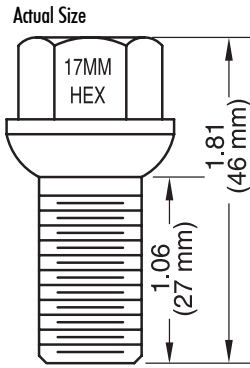
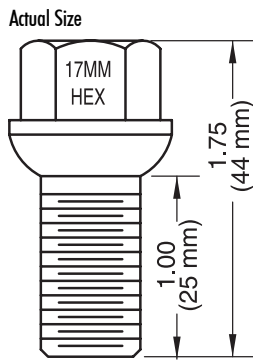

Dacromet
44mm - Overall
25mm - Shank

Dacromet
46 mm - Overall
27 mm - Shank

SIZE	PART#
14mm 1.50 RH	20-4221-B

SIZE	PART#
14mm 1.50 RH	20-4227-B

Boxes of 20 **\$1.59** each

Boxes of 20 **\$1.59** each

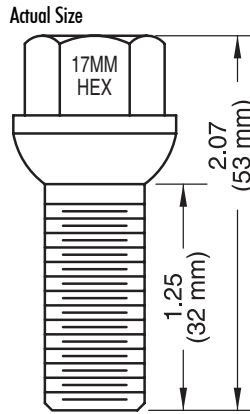

Dacromet
53mm - Overall
32mm - Shank

SIZE	PART#
14mm 1.50 RH	20-4261-B

Boxes of 20 **\$1.89** each

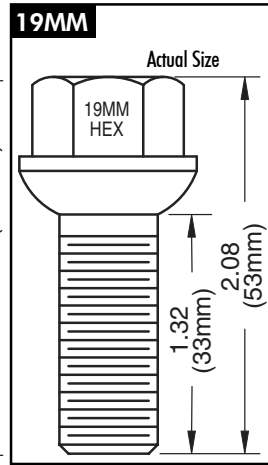

Dacromet
53mm - Overall
33mm - Shank

SIZE	PART#
14mm 1.50 RH	20-4269-B

Boxes of 20 **\$1.99** each

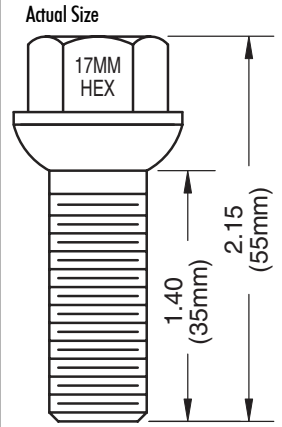

Dacromet
55mm - Overall
35mm - Shank

SIZE	PART#
14mm 1.50 RH	20-4270-B

Boxes of 20 **\$1.99** each

* Dacromet coating is a dull silver finish that provides a high corrosion resistance (500 hr salt spray). As specified by Mercedes Benz factory.

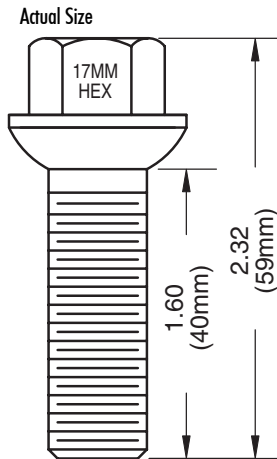

Dacromet
59mm - Overall
40mm - Shank

SIZE	PART#
14mm 1.50 RH	20-4289-B

Boxes of 20 **\$2.79** each

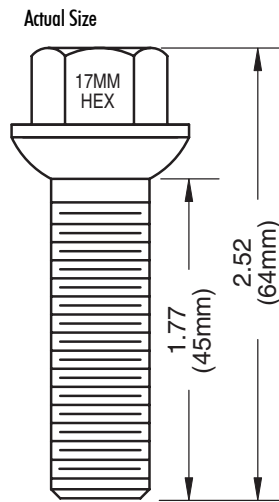

Dacromet
64mm - Overall
45mm - Shank

SIZE	PART#
14mm 1.50 RH	20-4302-B

Boxes of 20 **\$2.79** each

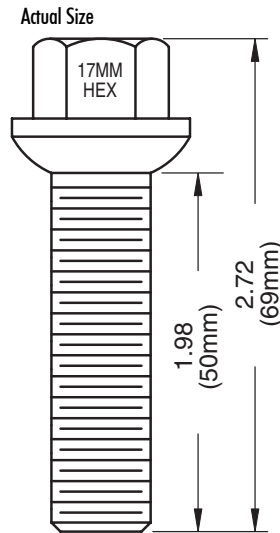

Dacromet
69mm - Overall
50mm - Shank

SIZE	PART#
14mm 1.50 RH	20-4308-B

Boxes of 20 **\$2.79** each

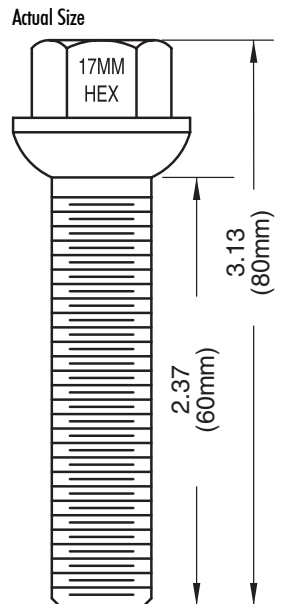

Dacromet
80mm - Overall
60mm - Shank

SIZE	PART#
14mm 1.50 RH	20-4315-B

Boxes of 20 **\$2.99** each

Orders less than \$50.00 are subject to a \$10.00 small order fee. Special large quantity pricing available on request.

LUG BOLTS

BALL SEAT LUG BOLTS

Chrome 12mm

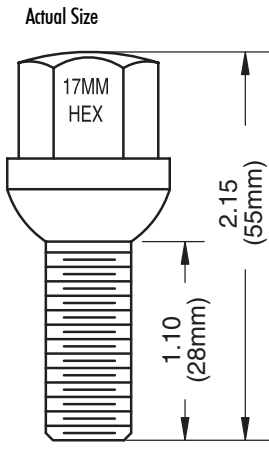

\$1.69
each
Boxes of 20

\$1.25
each
Quantity of 100

Short Ball Seat Early Chromed Lug Bolt
Normally used on early factory Mercedes 14" alloy wheels up thru 1985 models

SIZE	PART#
12mm 1.50 RH	19-12529-B*

*Formerly Part#99-0115

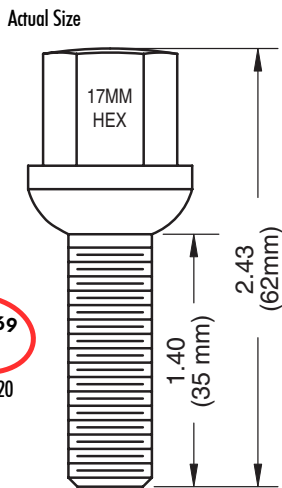

\$1.79
each
Boxes of 20

\$1.39
each
Quantity of 100

12mm Ball Seat Chromed Lug Bolt
62mm - Overall
35mm - Shank

SIZE	PART#
12mm 1.50 RH	19-12535-B

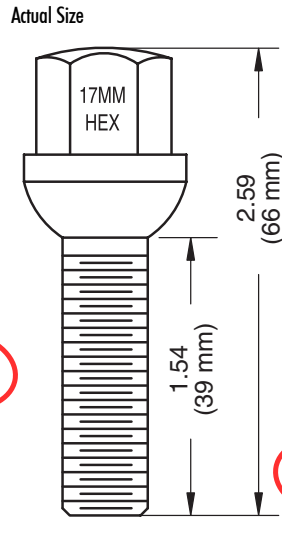

\$1.99
each
Boxes of 20

\$1.59
each
Quantity of 100

Medium Ball Seat 190/300 Chromed Lug Bolt
Normally used on late, flat faced style factory Mercedes alloy wheels

SIZE	PART#
12mm 1.50 RH	19-12539-B*

*Formerly Part#99-0815

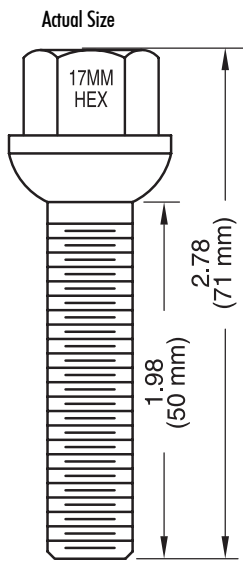

\$2.29
each
Boxes of 20

\$1.99
each
Quantity of 100

SL Spacer Chromed Lug Bolt
Normally used with our SL spacer
see page #36

SIZE	PART#
12mm 1.50 RH	19-12550-B*

*Formerly Part#99-0817

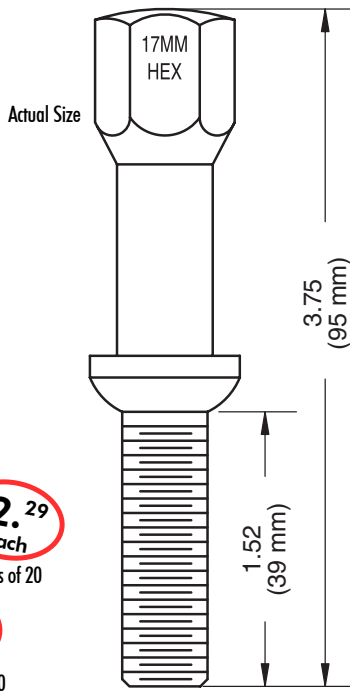

\$2.49
each
Boxes of 20

\$1.99
each
Quantity of 100

Extra Long Ball Seat 560 Chromed Lug Bolt
Normally used on late, 560 series flat faced style factory Mercedes alloy wheels

SIZE	PART#
12mm 1.50 RH	19-12539E-B*

*Formerly Part#99-0816

Orders less than \$50.00 are subject to a \$10.00 small order fee. Special large quantity pricing available on request.

LUG BOLTS

BALL SEAT LUG BOLTS

Chrome 14mm

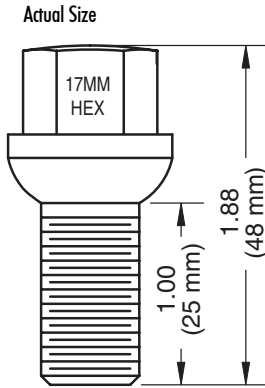

14mm Ball Seat Chromed Lug Bolt
48mm - Overall
25mm - Shank

SIZE	PART#
14mm 1.50 RH	19-14525-B

Boxes of 20 **\$1.49** each

Quantity of 100 **\$1.19** each

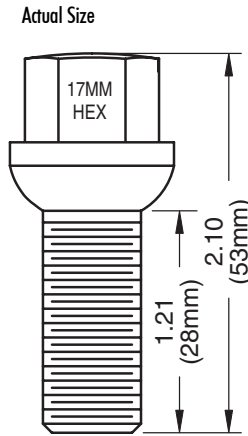

14mm Ball Seat Chromed Lug Bolt
53mm - Overall
28mm - Shank

SIZE	PART#
14mm 1.50 RH	19-14528-B

Boxes of 20 **\$1.69** each

Quantity of 100 **\$1.25** each

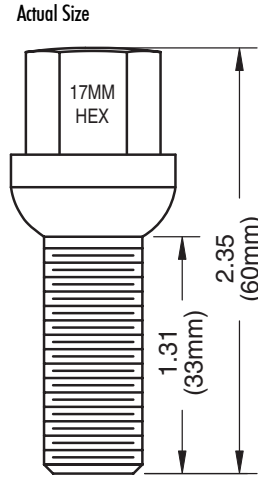

14mm Ball Seat Chromed Lug Bolt
60mm - Overall
33mm - Shank

SIZE	PART#
14mm 1.50 RH	19-14533-B

Boxes of 20 **\$1.79** each

Quantity of 100 **\$1.39** each

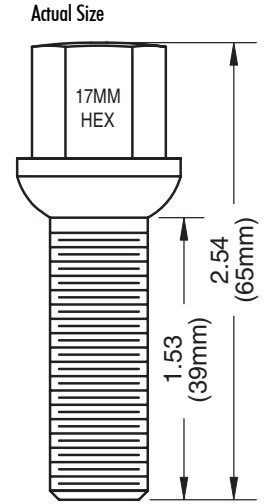

14mm Ball Seat Chromed Lug Bolt
65mm - Overall
39mm - Shank

SIZE	PART#
14mm 1.50 RH	19-14539-B

Boxes of 20 **\$1.99** each

Quantity of 100 **\$1.59** each

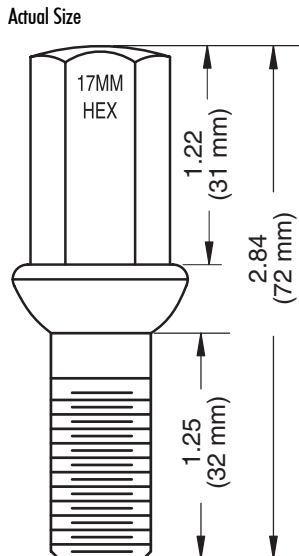

14mm Ball Seat 140 Series Chromed Lug Bolt
Normally used on aftermarket Mercedes alloy wheels
72mm - Overall
32mm - Shank

SIZE	PART#
14mm 1.50 RH	19-14532E-B*

*Formerly Part#99-9116

Boxes of 20 **\$2.99** each

Quantity of 100 **\$2.39** each

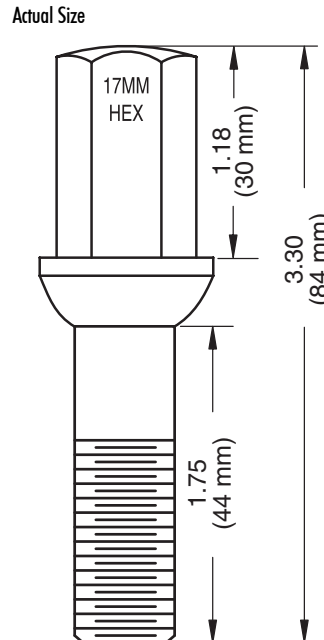

14mm Ball Seat 140 Series Chromed Lug Bolt
Normally used on factory Mercedes alloy wheels
84mm - Overall
44mm - Shank

SIZE	PART#
14mm 1.50 RH	19-14544E-B*

*Formerly Part#99-8116

Boxes of 20 **\$3.49** each

Quantity of 100 **\$2.99** each

STUDS

SCREW IN WHEEL STUDS

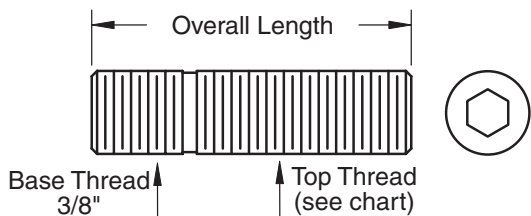

BASE THREAD		TOP THREAD		OVERALL LENGTH	PART#
12mm 1.50	RH	12mm 1.50	RH	1-1/2"	2800
12mm 1.50	RH	12mm 1.50	RH	1-3/4"	2800L
12mm 1.50	RH	12mm 1.50	RH	2-1/4"	2800XL
12mm 1.25	RH	12mm 1.25	RH	1-3/4"	2801
14mm 1.50	RH	1/2" x 20	RH	1-1/2"	2802
14mm 1.50	RH	14mm 1.50	RH	1-1/2"	2890
14mm 1.50	RH	14mm 1.50	RH	1-1/2"	2890L
14mm 1.50	RH	14mm 1.50	RH	1-1/2"	2890XL
1/2" x 20	RH	1/2" x 20	RH	1-1/2"	2803

Note: Hex key hole 7/32" standard

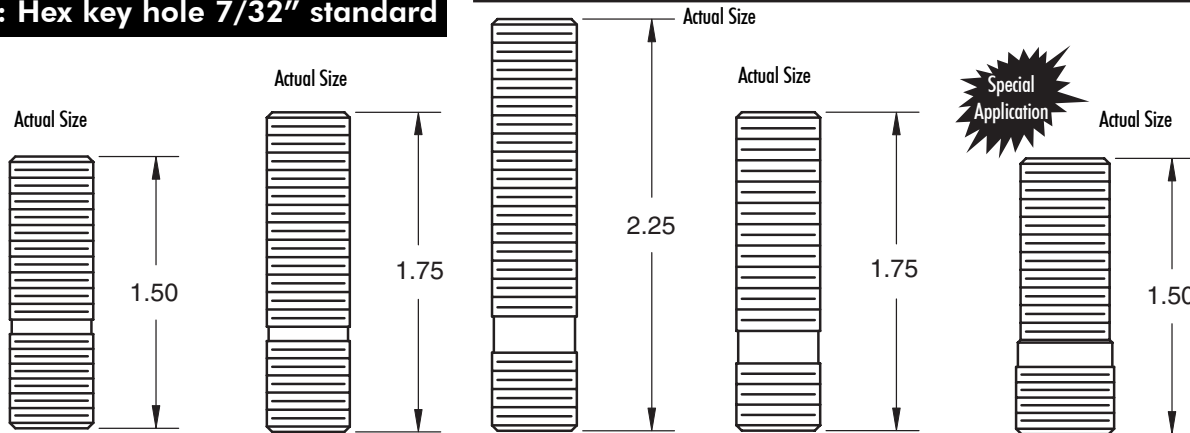

Part # 2800

Top thread 12mm 1.50 RH
Base thread 12mm 1.50 RH

.49¢
each

Part # 2800L

Top thread 12mm 1.50 RH
Base thread 12mm 1.50 RH

.51¢
each

Part # 2800XL

Top thread 12mm 1.50 RH
Base thread 12mm 1.50 RH

.77¢
each

Part # 2801

Top thread 12mm 1.25 RH
Base thread 12mm 1.25 RH

.51¢
each

Part # 2802

Top thread 1/2" x 20 RH
Base thread 14mm 1.50 RH

.51¢
each

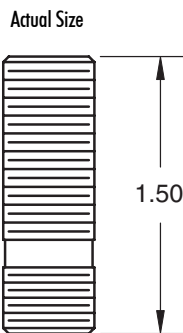

Part # 2803

Top thread 1/2" x 20 RH
Base thread 1/2" x 20 RH

.77¢
each

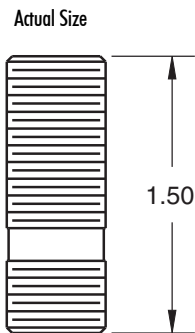

Part # 2890

Top thread 14mm 1.50 RH
Base thread 14mm 1.50 RH

.69¢
each

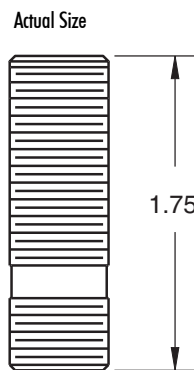

Part # 2890L

Top thread 14mm 1.50 RH
Base thread 14mm 1.50 RH

.79¢
each

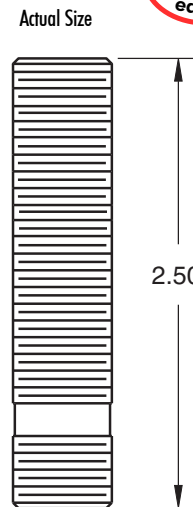

Part # 2890XL

Top thread 14mm 1.50 RH
Base thread 14mm 1.50 RH

.85¢
each

GENERIC

Standard Mag/Zinc #5481

Actual Size
Bags of 100

.08^c
each

Larger Mag/Chrome #5485C

Actual Size
Bags of 100

.28^c
each

Duplex Mag/Zinc #5482

Actual Size
Bags of 100

.08^c
each

5/8" MAG

5/8" Mag & Weld #5484C
Chromed

Actual Size

.28^c
each

Bags of 100

DUALEE

Chromed #5498C

Actual Size

.99^c
each

Box of 100

CONVERSION

#5478

Not Actual Size

.49^c
each

Bags of 100

Actual Size

Lets you use US 60° lug nuts on wheels drilled with German style ball seat holes. Often used with screw in wheel studs.

CRAGAR

Centered/Chrome #5486

Actual Size

.19^c
each

Bags of 100

Offset/Chrome #5487

Actual Size

.25^c
each

Bags of 100

ET STYLE

Centered/Chrome #5492

Actual Size

.49^c
each

Bags of 100

Offset/Chrome #5490

Actual Size

.49^c
each

Bags of 100

KEYSTONE

Centered/Chrome #5488

Actual Size

.39^c
each

Bags of 100

Offset/Chrome #5489

Actual Size

.39^c
each

Bags of 100

WHEEL LOCKS

Not to scale

Actual Size

.830

60°

.630

Set of 4

**Conical Seat Style
Open End**

SIZE	PART#
1/2" RH	1253
12mm 1.25 RH	1255
12mm 1.50 RH	1256
14mm 2.0 RH	1257
12mm 1.75 RH	1259
14mm 1.50 RH	1258

\$4.25 set

Not to scale

Actual Size

1.23

60°

.630

Set of 4

**Conical Seat Style
Closed End**

SIZE	PART#
7/16" RH	1221
1/2" RH	1223
12mm 1.25 RH	1225
12mm 1.50 RH	1226
12mm 1.75 RH	1229
14mm 1.50 RH	1228

\$4.99 set

Not to scale

Actual Size

1.63

60°

.630

Set of 4

**Conical Seat Style Long
Closed End**

SIZE	PART#
12mm 1.75 RH	1229L
14mm 1.50 RH	1228L
14mm 2.00 RH	1286L

\$5.49 set

TRUCK & SUV

Not to scale

Actual Size

2.00

60°

.630

Set of 4

**Conical Seat Style
Extra Long Closed End**

SIZE	PART#
14mm 1.50 RH	1228XL
14mm 2.0" RH	1286XL
9/16" RH	1269XL

\$5.99 set

**While
Quantities
Last**

Not to scale

Actual Size

1.31

.600

.670

1/8"

Set of 4

**Standard
Mag Style**

SIZE	PART#
7/16" RH	1231
1/2" RH	1233
12mm 1.25 RH	1235
12mm 1.50 RH	1236

\$4.99 set

GEAR STYLE WHEEL LOCKS

CONE SEAT

12MM

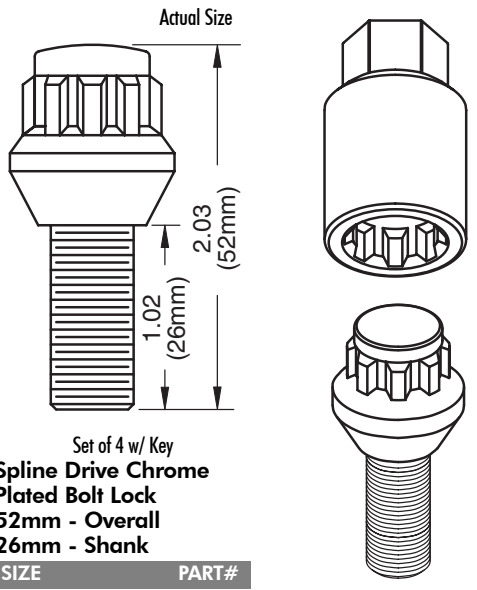

Set of 4 w/ Key
**Spline Drive Chrome
 Plated Bolt Lock**
 52mm - Overall
 26mm - Shank

SIZE	PART#
12mm 1.50 RH	24-1226-C

\$5.99
set

14MM

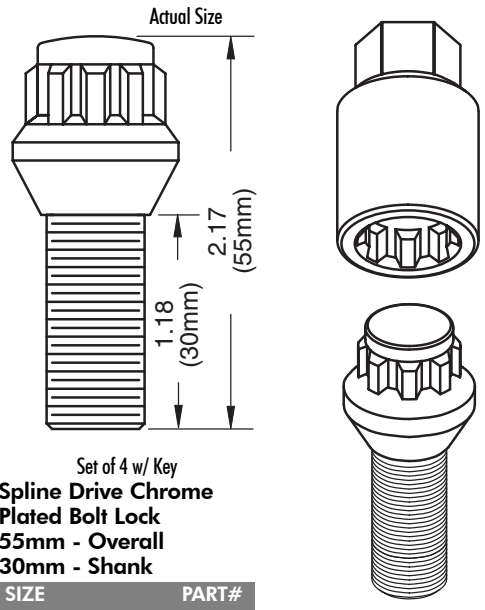

Set of 4 w/ Key
**Spline Drive Chrome
 Plated Bolt Lock**
 55mm - Overall
 30mm - Shank

SIZE	PART#
14mm 1.50 RH	24-1430-C

\$5.99
set

BALL SEAT

12MM

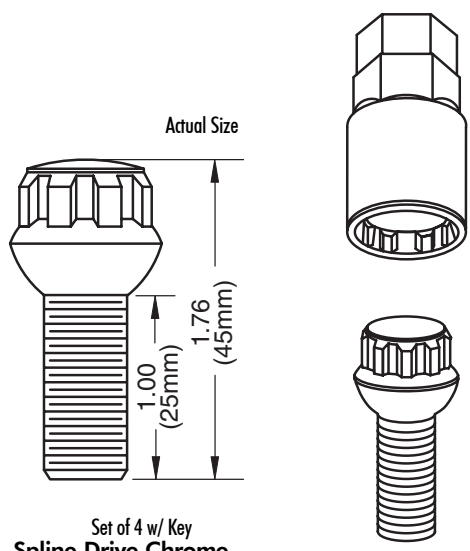

Set of 4 w/ Key
**Spline Drive Chrome
 Plated Bolt Lock**
 45mm - Overall
 25mm - Shank

SIZE	PART#
12mm 1.50 RH	24-1425-B

\$5.99
set

14MM

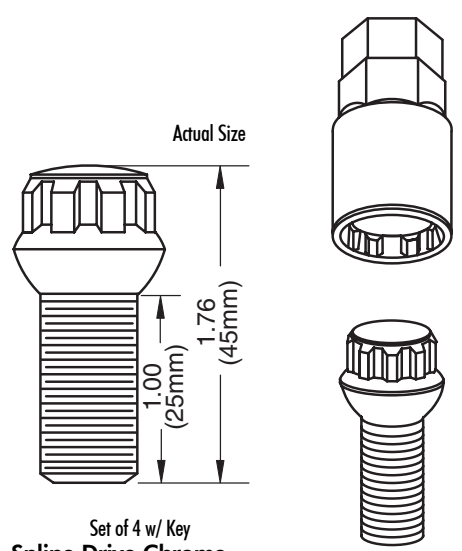

Set of 4 w/ Key
**Spline Drive Chrome
 Plated Bolt Lock**
 45mm - Overall
 25mm - Shank

SIZE	PART#
14mm 1.50 RH	24-1225-B

\$5.99
set

RAD BOLT LOCKS

GEAR STYLE BOLT LOCKS

\$19.95
Per set of 4

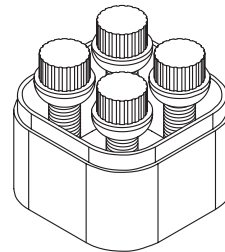

Made by one of Germany's top rated fastener manufacturers who has O.E. Contracts with several of Europe's widely recognized automobile manufacturers. Finished in Mercedes Benz specified Dacromet coating.

* Dacromet coating is a dull silver finish that provides a high corrosion resistance (500 hr salt spray). As specified by Mercedes Benz factory.

<p>Actual Size</p> <p>Set of 4 w/ Key</p> <p>Ball Seat Bolt Lock</p> <table border="1"> <tr><th>SIZE</th><th>PART#</th></tr> <tr><td>12mm 1.50 RH</td><td>22-2051-B</td></tr> </table>	SIZE	PART#	12mm 1.50 RH	22-2051-B	<p>Actual Size</p> <p>Set of 4 w/ Key</p> <p>Ball Seat Bolt Lock</p> <table border="1"> <tr><th>SIZE</th><th>PART#</th></tr> <tr><td>12mm 1.50 RH</td><td>22-2061-B</td></tr> </table>	SIZE	PART#	12mm 1.50 RH	22-2061-B	<p>Actual Size</p> <p>Set of 4 w/ Key</p> <p>Ball Seat Bolt Lock</p> <table border="1"> <tr><th>SIZE</th><th>PART#</th></tr> <tr><td>12mm 1.50 RH</td><td>22-2091-B</td></tr> </table>	SIZE	PART#	12mm 1.50 RH	22-2091-B	<p>Actual Size</p> <p>Set of 4 w/ Key</p> <p>Ball Seat Bolt Lock</p> <table border="1"> <tr><th>SIZE</th><th>PART#</th></tr> <tr><td>12mm 1.50 RH</td><td>22-2145-B</td></tr> </table>	SIZE	PART#	12mm 1.50 RH	22-2145-B
SIZE	PART#																		
12mm 1.50 RH	22-2051-B																		
SIZE	PART#																		
12mm 1.50 RH	22-2061-B																		
SIZE	PART#																		
12mm 1.50 RH	22-2091-B																		
SIZE	PART#																		
12mm 1.50 RH	22-2145-B																		

Shown with Key

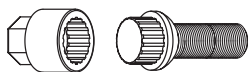

Shown with Chrome bolt lock cover

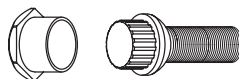

See page #31 for Chrome Bolt cover

<p>Actual Size</p> <p>Set of 4 w/ Key</p> <p>Ball Seat Bolt Lock</p> <table border="1"> <tr><th>SIZE</th><th>PART#</th></tr> <tr><td>14mm 1.5 RH</td><td>22-2225-B</td></tr> </table>	SIZE	PART#	14mm 1.5 RH	22-2225-B	<p>Actual Size</p> <p>Set of 4 w/ Key</p> <p>Ball Seat Bolt Lock</p> <table border="1"> <tr><th>SIZE</th><th>PART#</th></tr> <tr><td>14mm 1.5 RH</td><td>22-2223-B</td></tr> </table>	SIZE	PART#	14mm 1.5 RH	22-2223-B	<p>Actual Size</p> <p>Set of 4 w/ Key</p> <p>Ball Seat Bolt Lock</p> <table border="1"> <tr><th>SIZE</th><th>PART#</th></tr> <tr><td>14mm 1.50 RH</td><td>22-2263-B</td></tr> </table>	SIZE	PART#	14mm 1.50 RH	22-2263-B	<p>Actual Size</p> <p>Set of 4 w/ Key</p> <p>Ball Seat Bolt Lock</p> <table border="1"> <tr><th>SIZE</th><th>PART#</th></tr> <tr><td>14mm 1.50 RH</td><td>22-2275-B</td></tr> </table>	SIZE	PART#	14mm 1.50 RH	22-2275-B	<p>Actual Size</p> <p>Set of 4 w/ Key</p> <p>Ball Seat Bolt Lock</p> <table border="1"> <tr><th>SIZE</th><th>PART#</th></tr> <tr><td>14mm 1.50 RH</td><td>22-2304-B</td></tr> </table>	SIZE	PART#	14mm 1.50 RH	22-2304-B
SIZE	PART#																							
14mm 1.5 RH	22-2225-B																							
SIZE	PART#																							
14mm 1.5 RH	22-2223-B																							
SIZE	PART#																							
14mm 1.50 RH	22-2263-B																							
SIZE	PART#																							
14mm 1.50 RH	22-2275-B																							
SIZE	PART#																							
14mm 1.50 RH	22-2304-B																							

RAD BOLT LOCKS

GEAR STYLE BOLT LOCKS

\$19.95
Per set of 4

Actual Size

Set of 4 w/ Key

Actual Size

Set of 4 w/ Key

Actual Size

Set of 4 w/ Key

Actual Size

Set of 4 w/ Key

Actual Size

Set of 4 w/ Key

Cone Seat Bolt Lock			Cone Seat Bolt Lock			Cone Seat Bolt Lock			Cone Seat Bolt Lock			Cone Seat Bolt Lock		
SIZE	PART#		SIZE	PART#		SIZE	PART#		SIZE	PART#		SIZE	PART#	
12mm 1.50 RH	22-2012-C		12mm 1.50 RH	22-2083-C		12mm 1.50 RH	22-2111-C		12mm 1.50 RH	22-2149-C		12mm 1.50 RH	22-2165-C	

\$19.95
Per set of 4

Actual Size

Set of 4 w/ Key

Actual Size

Set of 4 w/ Key

Actual Size

Set of 4 w/ Key

Cone Seat Bolt Lock			Cone Seat Bolt Lock			Cone Seat Bolt Lock		
SIZE	PART#		SIZE	PART#		SIZE	PART#	
14mm 1.50 RH	22-2215-C		14mm 1.50 RH	22-2242-C		14mm 1.50 RH	22-2262-C	

19MM CHROME BOLT LOCK COVER

Part# 99-9999-R

Chrome plated plastic covers for RAD gear style bolt locks.

Each kit contains 4 chrome-plated bolt lock covers and 1 removal tool. They are packaged in a poly bag with an attractive header card.

Lug Cover Only

.69¢
each

Set of 4 w/ Puller

2.79
each

Not to scale

VALVE STEMS

VALVE STEMS



All Rubber

Chrome Sleeved Over Rubber

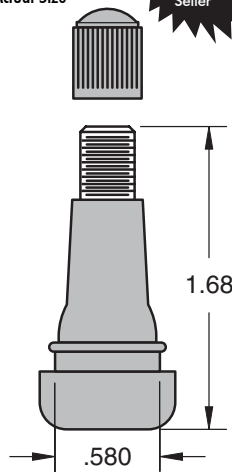
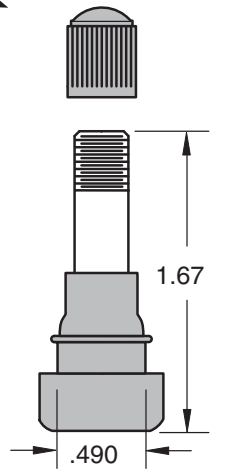
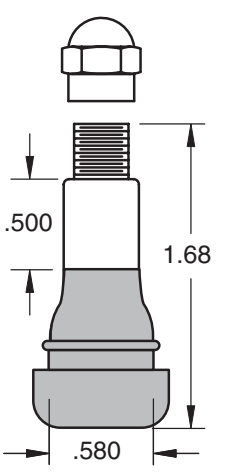
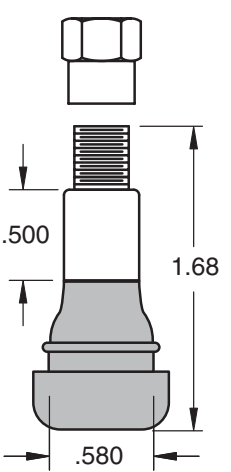
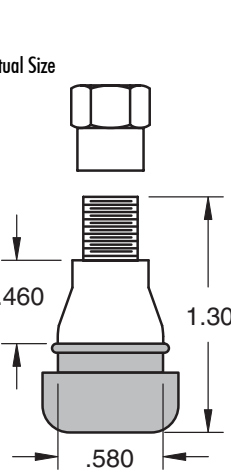
Industry's #1 (All Rubber) Seller

<p>Actual Size</p>  <p>Actual Size</p> 	<p>Actual Size</p> 	<p>Actual Size</p> 	<p>Actual Size</p> 
<p>All Rubber Small O.D. #29413* (TR 413) *Formerly Part #2904</p>	<p>High Pressure Rubber #29600-HP* (TR 600HP) *Formerly Part #2910-HP</p>	<p>Rubber w/Chrome Sleeve and Round Cap #29413-CR* (TR 413C) *Formerly Part #2902-R</p>	<p>Rubber w/Chrome Sleeve and Hex Cap #29413-CH* (TR 413C) *Formerly Part #2902-H</p>
<p>Boxes of 100 .16^c each</p> <p>Boxes of 1000 .14^c each</p>	<p>Boxes of 100 .75^c each</p>	<p>Boxes of 100 .34^c each</p> <p>Boxes of 1000 .23^c each</p>	<p>Boxes of 100 .34^c each</p> <p>Boxes of 1000 .24^c each</p>

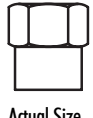
ACCESSORIES

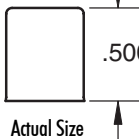
<p>Hex Head Cap, Chrome #2903H</p>  <p>Actual Size</p> <p>Boxes of 100 .12^c each</p> <p>Boxes of 1000 .10^c each</p>	<p>Round Head Cap, Chrome #2903R</p>  <p>Actual Size</p> <p>Boxes of 100 .10^c each</p> <p>Boxes of 1000 .08^c each</p>	<p>Valve Stem Sleeve, Chrome #2903S</p>  <p>Actual Size</p> <p>Boxes of 100 .10^c each</p> <p>Boxes of 1000 .08^c each</p>
---	---	---

Chrome Plastic Valve Stem Cap Sleeve

Actual Size

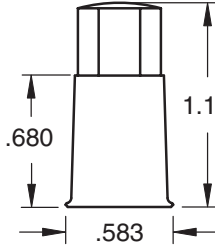

Actual Size

Boxes of 100 **.25^c** each

Boxes of 1000 **.19^c** each

Chrome cap/sleeve
#2903SSC

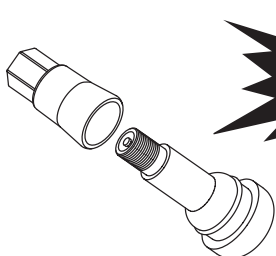

Covers much more of the rubber stem than the normal chrome sleeve stem!

Actual Size

VALVE STEMS

VALVE STEMS

Inner Mount
(Nut on bottom)

Outer Mount
(Nut on top)

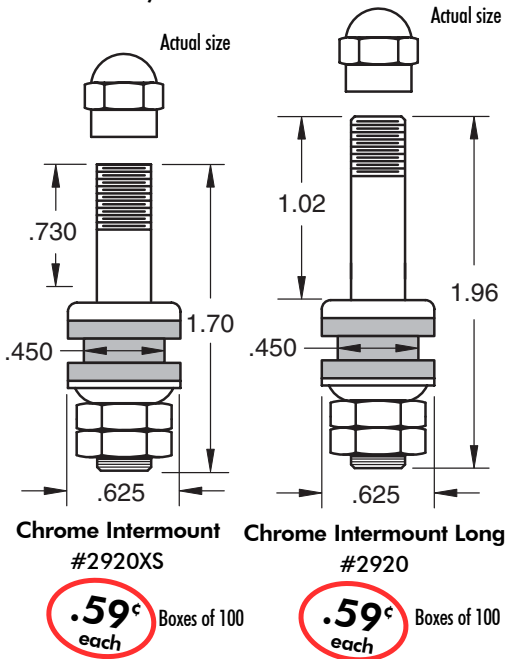

Chrome		Stainless
<p>Supplied with 2 grommets: 1 .450 O.D. 1 .630 O.D.</p> <p>Grommet</p>	<p>Actual size</p> <p>Chrome Low Profile Metal #29435* <i>*Formerly Part #2900</i></p> <p>.49^c each Boxes of 100</p>	<p>Actual size</p> <p>Stainless Low Profile Metal #29435S* <i>*Formerly Part #2900S</i></p> <p>.39^c each Boxes of 100</p>

90 Angle

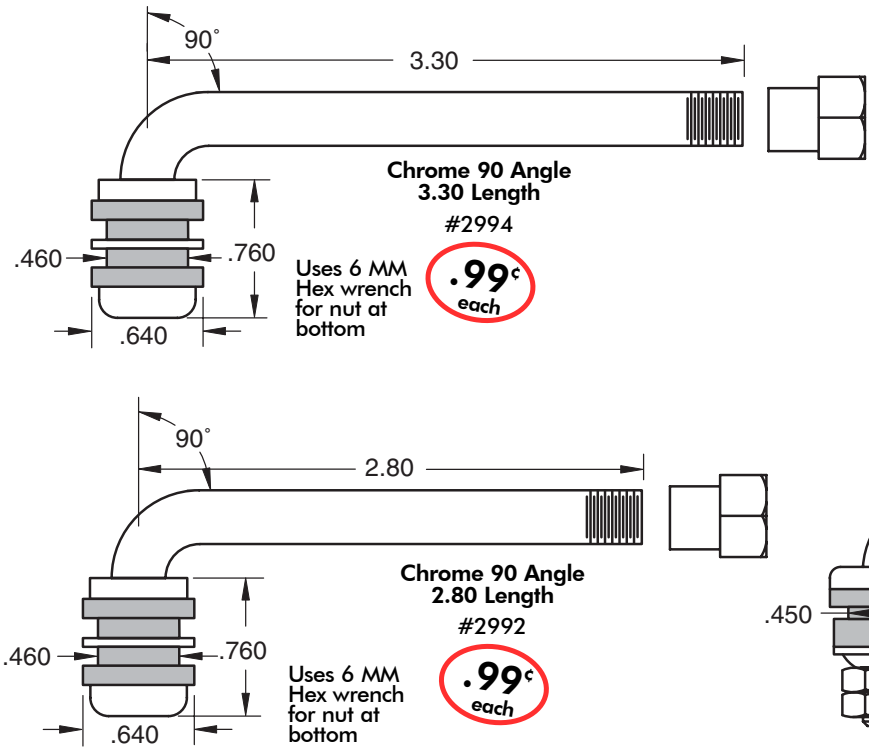

45 Angle

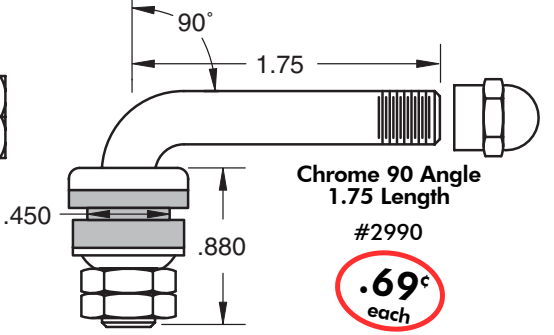
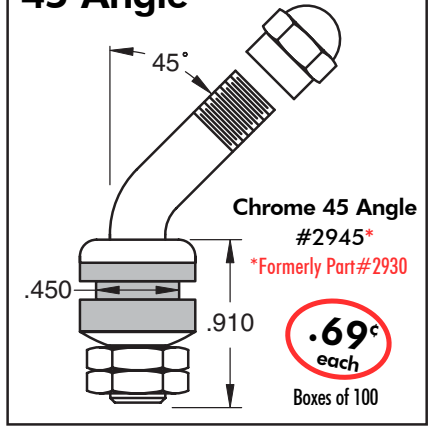

VALVE STEMS

VALVE STEMS

Flush mount valve stem for that show car look.

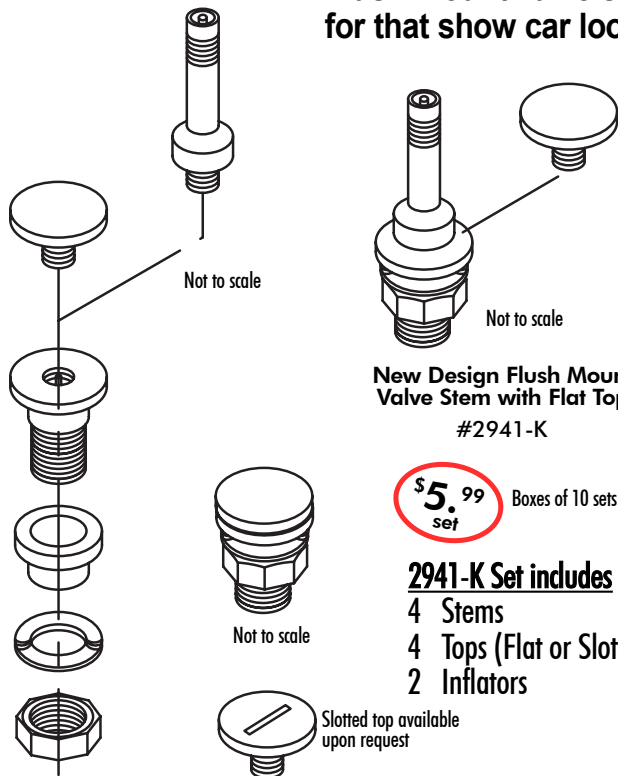

New Design Flush Mount Valve Stem with Flat Top
#2941-K

\$5.99 Boxes of 10 sets
set

2941-K Set includes
4 Stems
4 Tops (Flat or Slotted)
2 Inflators

Flush Mount Valve Stem Set

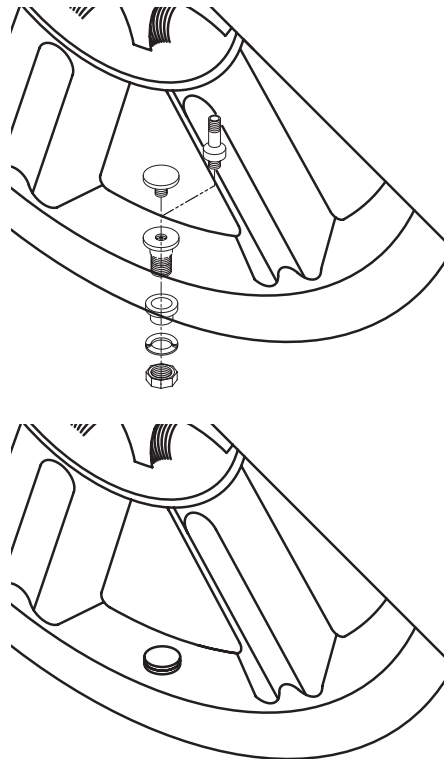

Special Application Valve Stems

For use when you have a wheel with an extra small diameter valve hole (i.e. 3 piece wheels or motorcycle wheels)

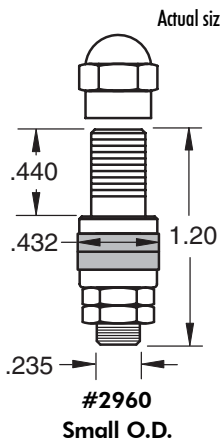

.65^c Boxes of 100
each

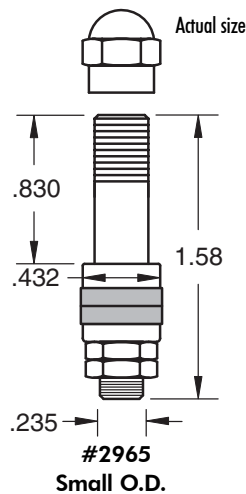

.65^c Boxes of 100
each

WHEEL INSERTS

BALL SEAT INSERTS

Ball Seat

WI510

Actual Size

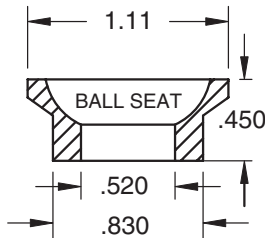

Commonly used on foreign aftermarket wheels and some U.S. wheels that have the smaller (.510") stud hole.

The (.510") I.D. stud hole **is not** the most popular size because it will not accept a 14mm stud.

Boxes of 100

.35^c
each

Ball Seat 14mm

WI100

Actual Size

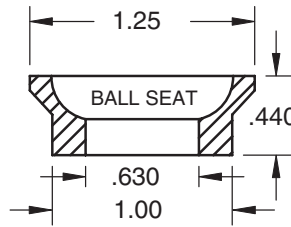

Commonly used on most U.S. aftermarket wheels that use the larger (.630) I.D. stud hole.

The (.630) I.D. stud hole size **is the most popular ball seat size** because it will accept a 14mm stud.

Boxes of 100

.69^c
each

Ball Seat O.E. Mercedes

WI8001

Actual Size

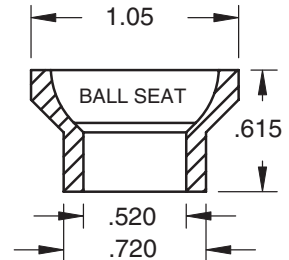

This insert is most commonly used in early factory O.E. Mercedes Benz 14" alloy wheels.

Often during the chrome plating process, the original inserts are lost or damaged. This insert is the exact replacement.

Boxes of 100

\$1.99
each

CONE SEAT INSERTS

Conical Seat

WI610

Actual Size

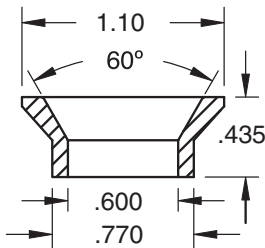

Commonly used on foreign aftermarket wheels and some U.S. wheels that use the smaller (.610") I.D. stud hole.

The (.610") I.D. stud hole **is not** the most popular size because it will not accept a 14mm stud.

Boxes of 100

.29^c
each

Conical Seat

WI630

Actual Size

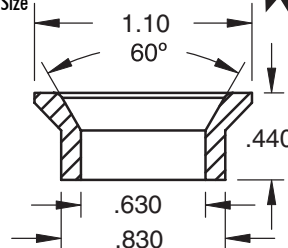

Commonly used on most U.S. aftermarket wheels that use the larger (.630") I.D. stud hole size.

The (.630") I.D. stud hole size **is the most popular size** because it will accept a 14mm stud.

Boxes of 100

.29^c
each

Oversized Insert

WI660

Actual Size

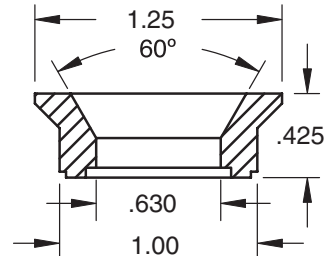

Commonly used when redrilling wheels to change from one bolt pattern to another.

The large 1.250" O.D. of the outer helps to cover up the old bolt pattern. This insert has the popular (.630") I.D. stud hole.

Boxes of 100

.69^c
each

Duplex Insert

WI690

Actual Size

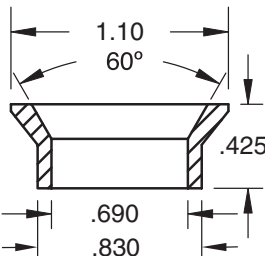

Commonly used on most U.S. aftermarket wheels for duplex (.690") I.D. stud hole.

Boxes of 100

.99^c
each

Universal Insert Conical Seat

WI691

Actual Size

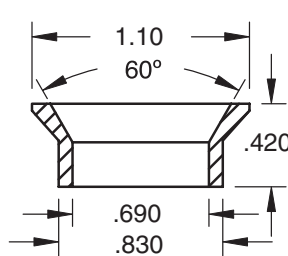

Optional (slightly smaller head) for most U.S. Aftermarket wheels that use duplex (.690") I.D. stud holes.

Boxes of 100

.99^c
each

Don't Forget...

Orders less than \$50.00 are subject to a \$10.00 small order fee. Special large quantity pricing available on request.

SPACERS

SPACERS

#C7100 4 and 5 lug Universal Thin Style Spacers

FITS 4 LUG	
METRIC SIZES	
98 mm	
100 mm	
108 mm	
110 mm	
114.3 mm	
120 mm	
STANDARD SIZES	
3-3/4"	
4"	
4-1/4"	
4-1/2"	
FITS 5 LUG	
METRIC SIZES	
100 mm	
108 mm	
112 mm	
114.3 mm	
115 mm	
120 mm	
STANDARD SIZES	
4"	
4-1/4"	
4-1/2"	
4-3/4"	

\$2.49
each

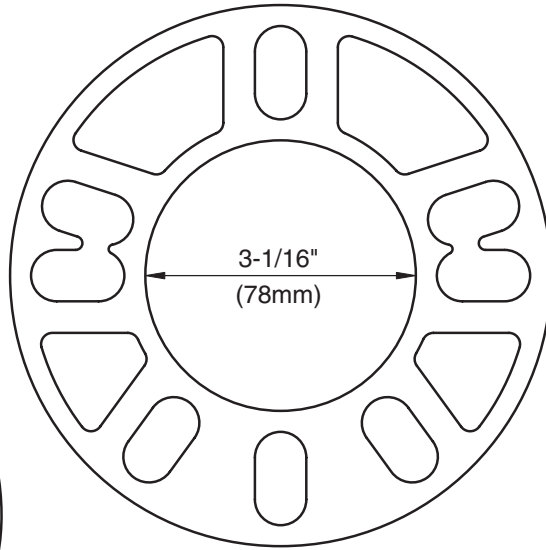
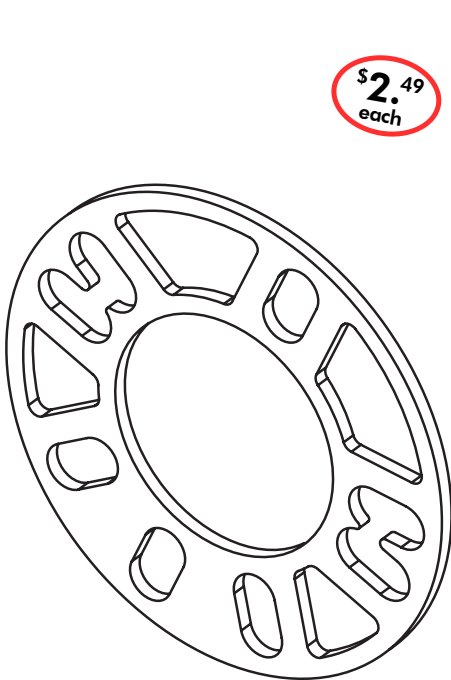

Spacer drawing
not to scale

Actual spacer
thickness

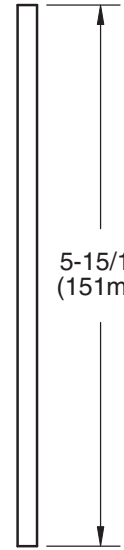

1/8"
(3mm)

#C7109 4 and 5 lug Universal Thin Style Spacers

FITS 4 LUG	
METRIC SIZES	
100 mm	
108 mm	
110 mm	
114.3 mm	
120 mm	
STANDARD SIZES	
3-3/4"	
4"	
4-1/4"	
4-1/2"	
FITS 5 LUG	
METRIC SIZES	
108 mm	
112 mm	
114.3 mm	
115 mm	
120 mm	
STANDARD SIZES	
4"	
4-1/4"	
4-1/2"	
4-3/4"	

\$2.49
each

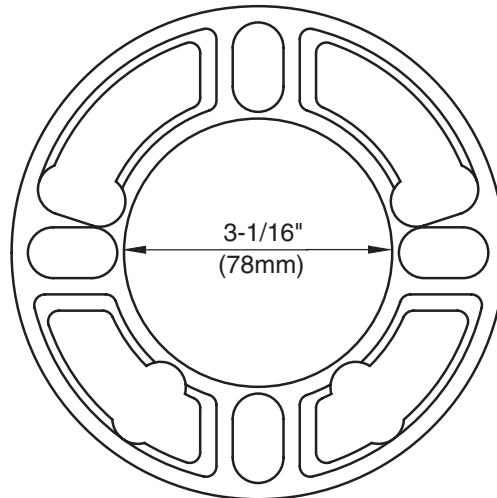
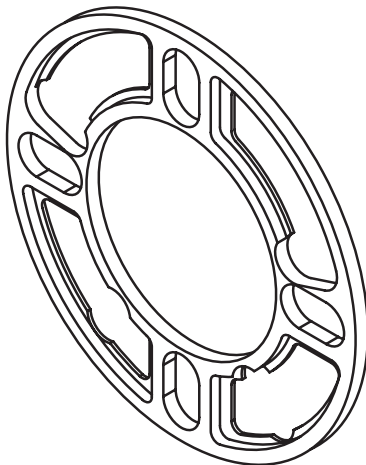

Spacer drawing
not to scale

Actual spacer
thickness

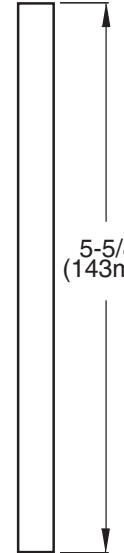

3/16"
(5mm)

SPACERS

#C7101 4 lug 1/4", Thick

Fits the following 5 bolt circles:

4 LUG	
FITS METRIC SIZES	
98 mm	
100 mm	
108 mm	
110 mm	
114.3 mm	
120 mm	
FITS STANDARD SIZES	
3-3/4"	
4"	
4-1/4"	
4-1/2"	

\$2.79
each

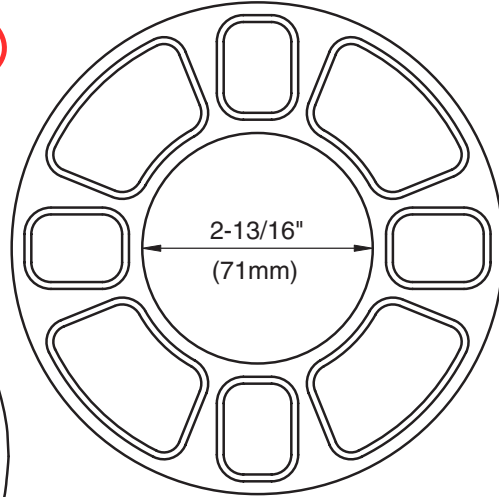
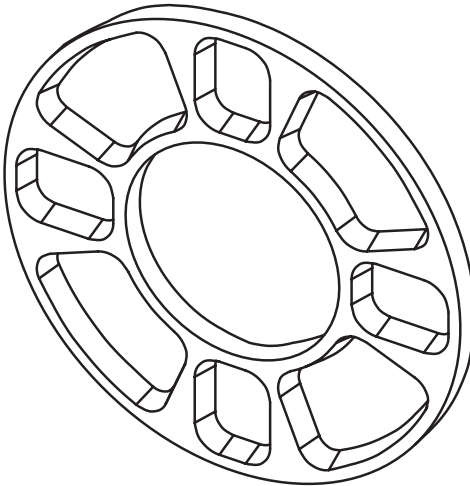

Spacer drawing not to scale

Actual spacer thickness

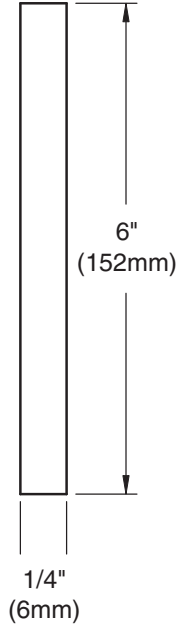

#C7102 5 lug 5/16" Thick

Fits the following 5 bolt circles:

5 LUG	
FITS METRIC SIZES	
108 mm	
112 mm	
114.3 mm	
115 mm	
120 mm	
130 mm	
FITS STANDARD SIZES	
4-1/4"	
4-1/2"	
4-3/4"	
5"	

\$2.79
each

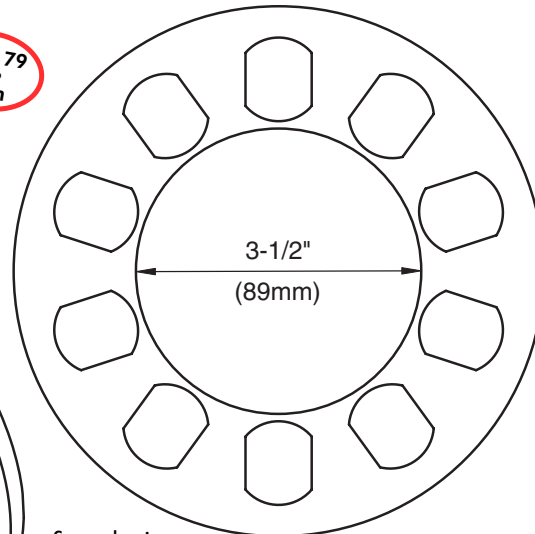
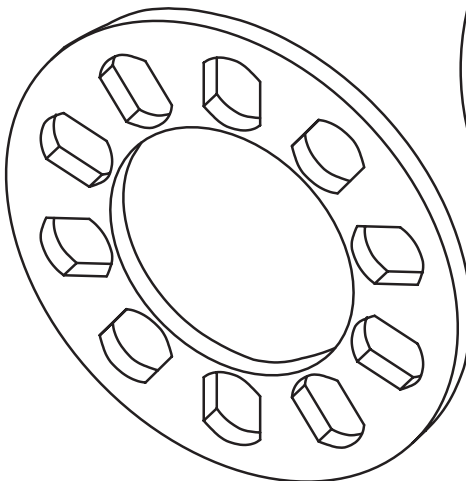

Spacer drawing not to scale

Actual spacer thickness

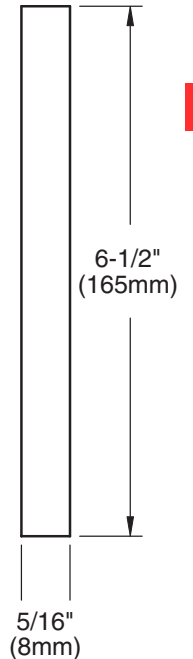

Orders less than \$50.00 are subject to a \$10.00 small order fee. Special large quantity pricing available on request.

SPACERS

SPACERS

#C7105 5 lug 5/16", Thick Small Bore

Fits the following 5 lug bolt circles:

5 LUG	
FITS METRIC SIZES	
100 mm	
108 mm	
112 mm	
114.3 mm	
115 mm	
120 mm	
FITS STANDARD SIZES	
4"	
4-1/4"	
4-1/2"	
4-3/4"	

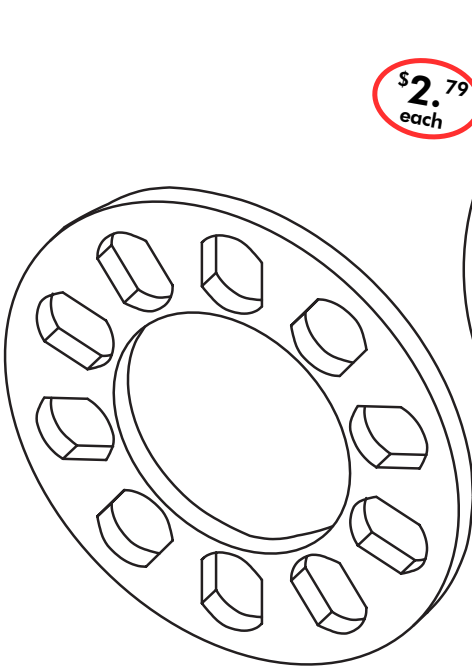

\$2.79
each

Spacer drawing
not to scale

Actual spacer
thickness

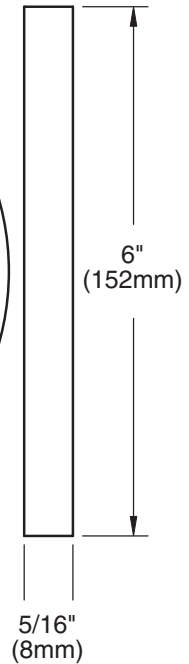

#C7106 5 lug 3/16", Thin Small Bore

Fits the following 5 bolt circles:

5 LUG	
FITS METRIC SIZES	
100 mm	
108 mm	
112 mm	
114.3 mm	
115 mm	
120 mm	
FITS STANDARD SIZES	
4"	
4-1/4"	
4-1/2"	
4-3/4"	

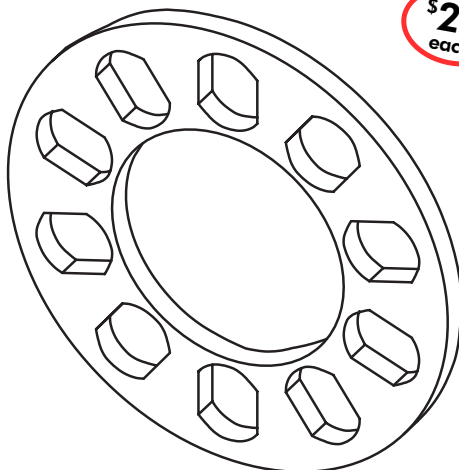

\$2.79
each

Spacer drawing
not to scale

Actual spacer
thickness

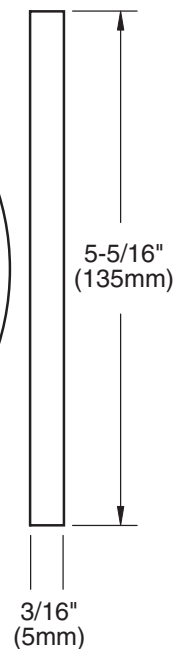

SPACERS

#C7110 5 lug 1/2" Thick

Fits the following 5 lug bolt circles:

5 LUG	
FITS METRIC SIZES	
108 mm	
112 mm	
114.3 mm	
115 mm	
120 mm	
130 mm	
FITS STANDARD SIZES	
4-1/4"	
4-1/2"	
4-3/4"	
5"	

\$3.99
each

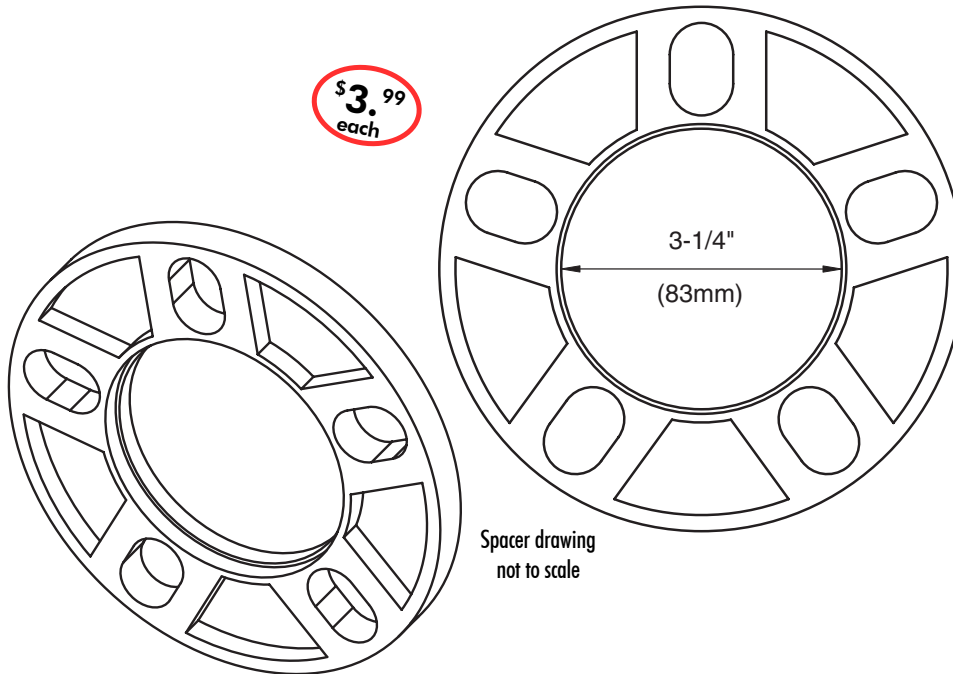

Spacer drawing not to scale

SPACERS

Actual spacer thickness

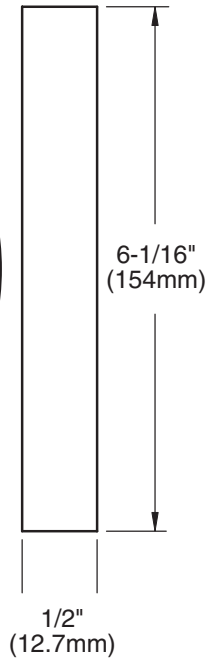

#C7103* Universal 5 on 5-1/2" & 6 on 5-1/2", 1/4" Thick

5 LUG	
FITS STANDARD SIZES	
5-1/2" (139.7mm)	
6 LUG	
FITS STANDARD SIZES	
5-1/2" (139.9mm)	

\$2.99
each

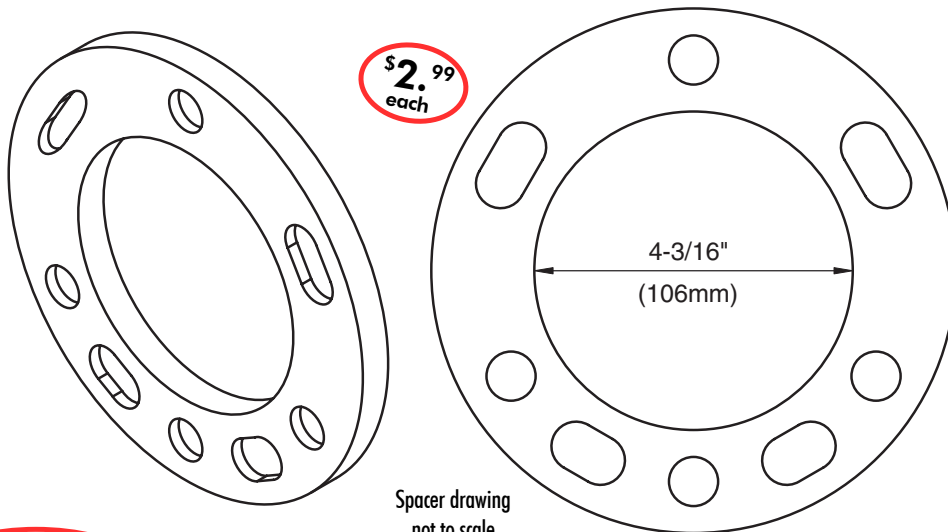

Spacer drawing not to scale

Actual spacer thickness

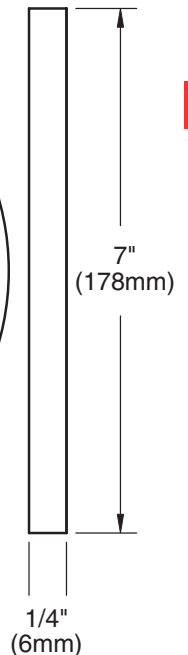

***To fit 5 on 135mm bolt pattern Available by 2004**

SPACERS

SPACERS

#C7104

8 Lug Trucks with 8 on 6-1/5" (165.1mm) bolt circle,
3/16" thick

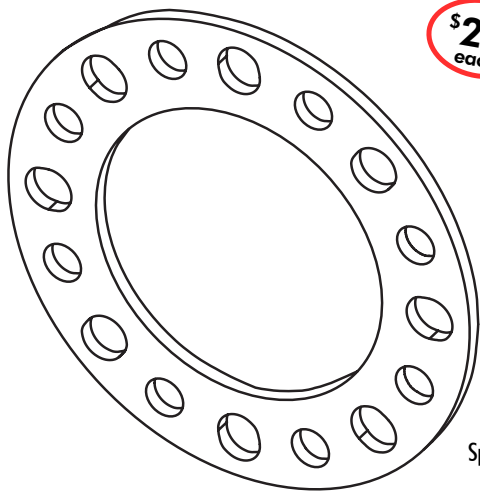

\$2.99
each

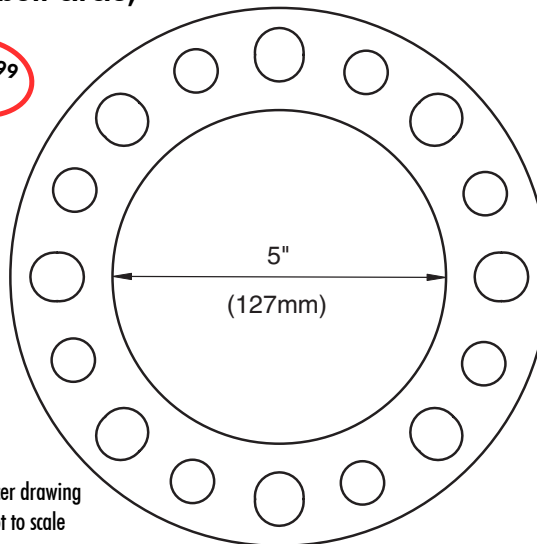

Spacer drawing
not to scale

Actual spacer
thickness

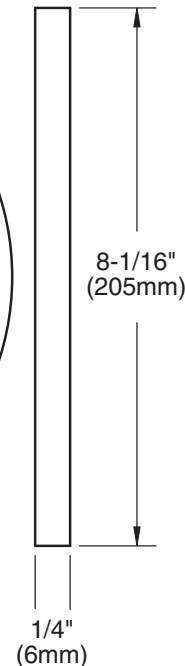

Did you know...

We can custom make special products for you. From rivets to body badges to center caps. With our in house graphic and engineering departments, we can work with you from conception to delivery of product.

A brief list of our major services

- Product Development
- Project Management
- Project Monitoring
- Single Contact
- Purchasing
- Packaging & Delivery



Prestige
WHEEL ACCESSORIES

(800) 854-6770 (877) LUG-NUTS

(714) 841-6333

Fax: (714) 841-6413

5 8 4 - 6 8 8 7

M-F 7:30AM - 4:30PM CALIF TIME

SPACERS

Billet Machined Special Application Hub Centric Spacers

#C5120

5 Lug BMW

5 on 120 mm bolt circle,
1/2" thick

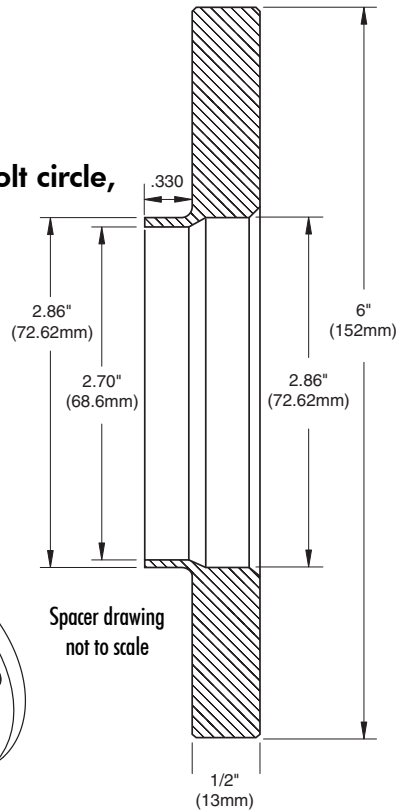

\$28.95
each

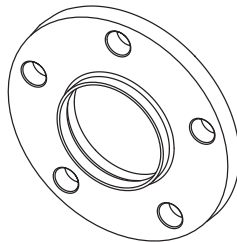

Spacer drawing
not to scale

#C5112

5 Lug Mercedes

5 on 112 mm bolt circle,
1/2" thick

**Fits a variety
of models.
Call for
details.**

\$28.95
each

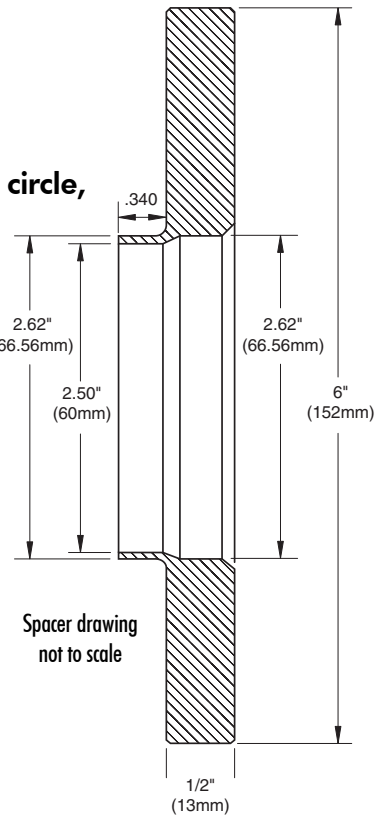
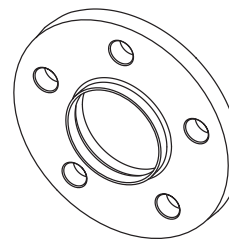

Spacer drawing
not to scale

#C-560-100 560 SL Style Spacer 20mm Thick Bolt Circle 5 x 112mm

Use with the special spacer bolts #99-0817 or #20-4169

Hub Centric - Fits the following
Mercedes-Benz chassis:

FITS MERCEDES CHASSIS#
107
114/115
116
123
126

\$34.95
each

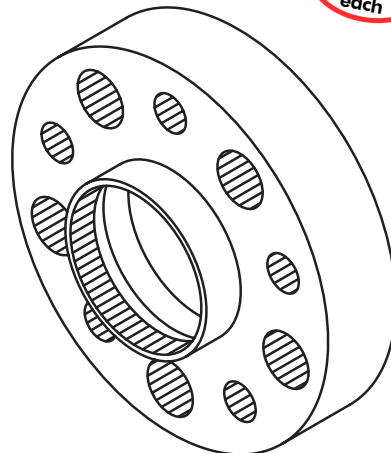

Spacer drawing
not to scale

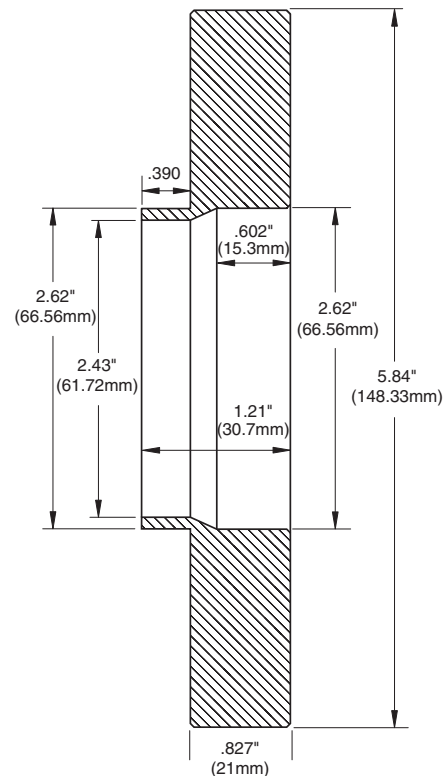

METAL CENTER CAPS

Push Thru Style, Chrome Closed or Open End

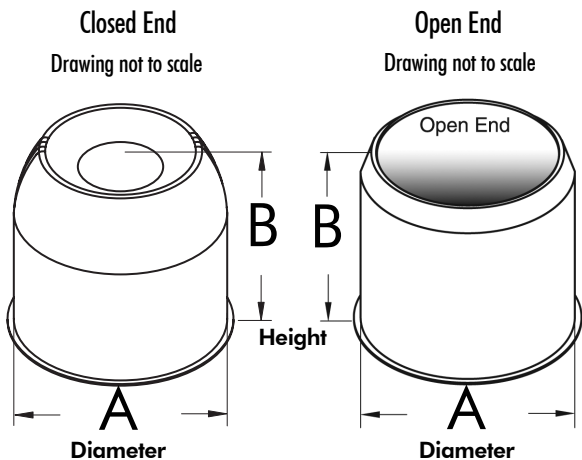

Small

Normally used on wheels with bolt circles: 5 on 4-1/2, 5 on 4-3/4, 5 on 5

A-DIAMETER	B-HEIGHT	CHROME CLOSED PART#	CHROME OPEN PART#
2-11/16" (2.675)	2-15/16"	P2675	
2-15/16" (2.950)	2-7/8"	P2950	
3-3/16" (3.195)	3-5/16"	P3195	
3-1/4" (3.250)	3-7/16"	P3250	
3-5/16" (3.330)	3-7/16"	P3300	P3300-0

\$1.49
each
Chrome Small Caps

*Stainless Steel finish available for special order. Ask for details.

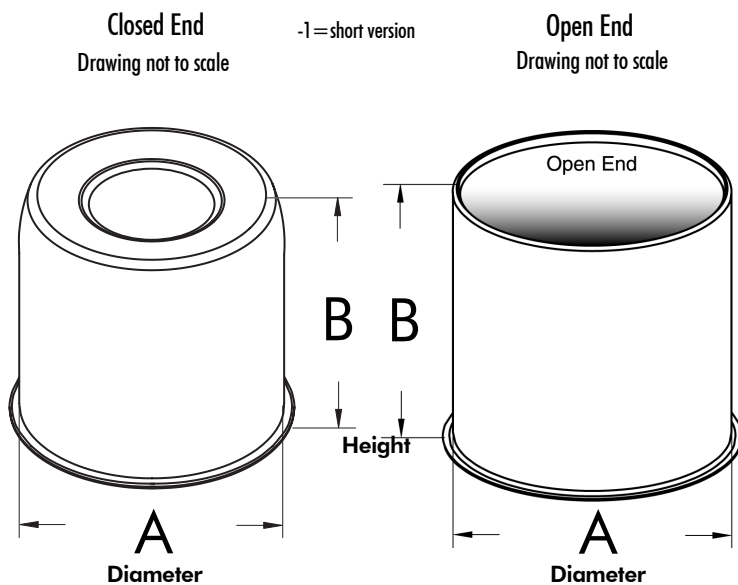

Medium

Normally used on wheels with bolt circles: 5 on 5-1/2, 6 on 5-1/2

A-DIAMETER	B-HEIGHT	CHROME CLOSED PART#	CHROME OPEN PART#
4-1/4" (4.255)	4-1/4"	P4255	P4255-0
4-1/4" (4.255)	3-1/2"	P4255-1	

\$1.89
each

*Stainless Steel finish available for special order. Ask for details.

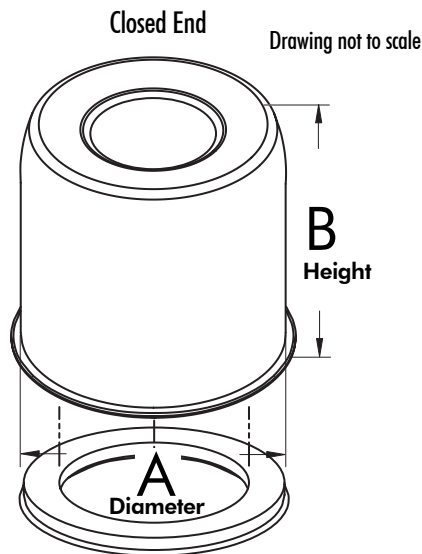

Chrome cap with Hub ring insert

Medium with Hubring insert

Normally used on wheels with bolt circles: 5 on 5-1/2, 6 on 5-1/2

A-DIAMETER	B-HEIGHT	CHROME CLOSED PART#	HUBRING O.D.	HUBRING I.D.
4-1/4" (4.255)	4-1/4"	P4255-HC	105.70mm	78.03mm

\$5.49
each

*Stainless Steel finish available for special order. Ask for details.

CAPS

METAL CENTER CAPS

Push Thru Style, Chrome Closed or Open End

Closed End
Drawing not to scale

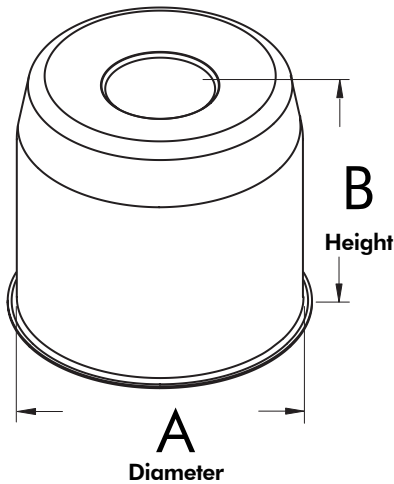

Open End
Drawing not to scale

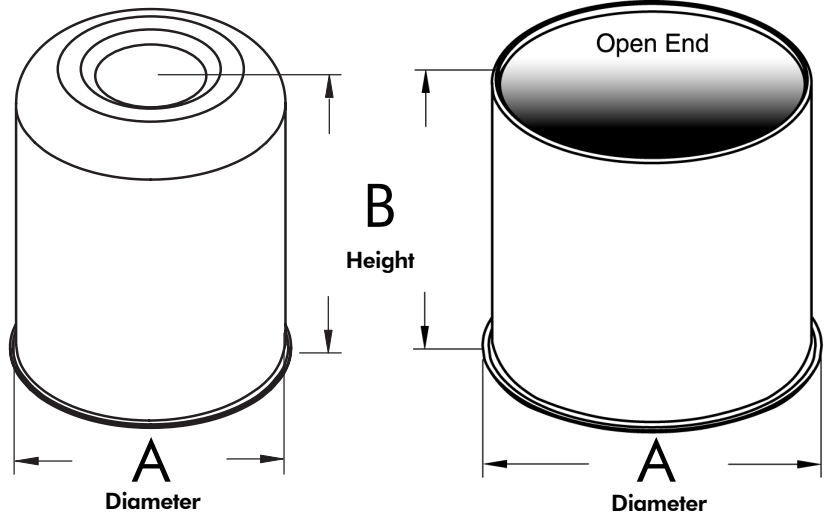

Large

Normally used on wheels with bolt circle: 8 on 6-1/2

A-DIAMETER	B-HEIGHT	CHROME CLOSED PART#	CHROME OPEN PART#
4-5/16" (4.900)	4-1/2"	P4900-2	P4900-0
5-5/32" (5.150)	5"	P5150	P5150-0
5-5/32" (5.150)	6-1/4"	P5150-2	

-2=tall version

\$3.99
each

*Stainless Steel finish available for special order. Ask for details.

CAPS

METAL CENTER CAPS

Closed End
Drawing not to scale

Open End
Drawing not to scale

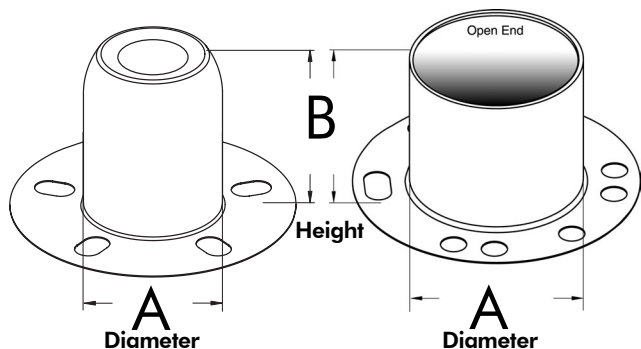

Small

Normally used on wheels with bolt circles: 5 on 4-1/2, 5 on 4-3/4, 5 on 5

A-DIAMETER	B-HEIGHT	CLOSED PART#	OPEN PART#
3-3/16" (3.187)	4-1/4"	D3187	D3187-0

\$2.99
each

Closed End
Drawing not to scale

Open End
Drawing not to scale

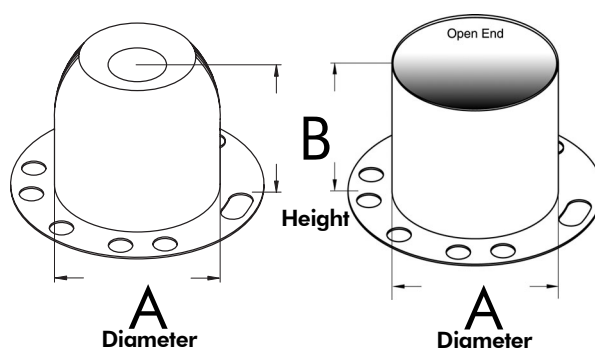

Medium

Normally used on wheels with bolt circles: 5 on 5-1/2, 6 on 5-1/2

A-DIAMETER	B-HEIGHT	CLOSED PART#	OPEN PART#
4-1/4" (4.250)	4"	D4250	D4250-0
4-1/4" (4.250)	3-1/2"		D4250-0-1

\$3.29
each

-1 = short version

Closed End
Drawing not to scale

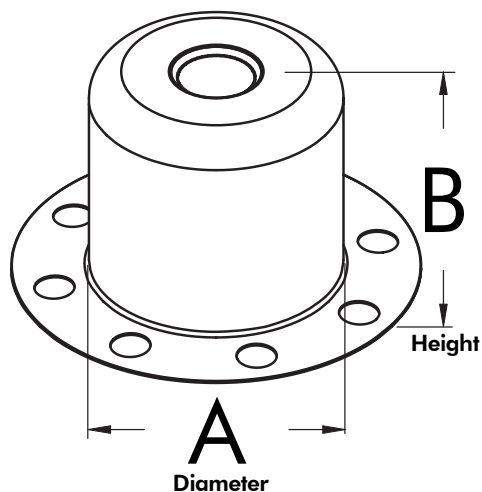

Medium

Normally used on wheels with bolt circle: 8 on 6-1/2

A-DIAMETER	B-HEIGHT	CLOSED PART#	OPEN PART#
4-7/8" (4.900)	4-1/2"	D4900*	D4900-0*

\$3.99
each

*Available by special order only.
Call for details.

STANDARD DUALEE CAPS

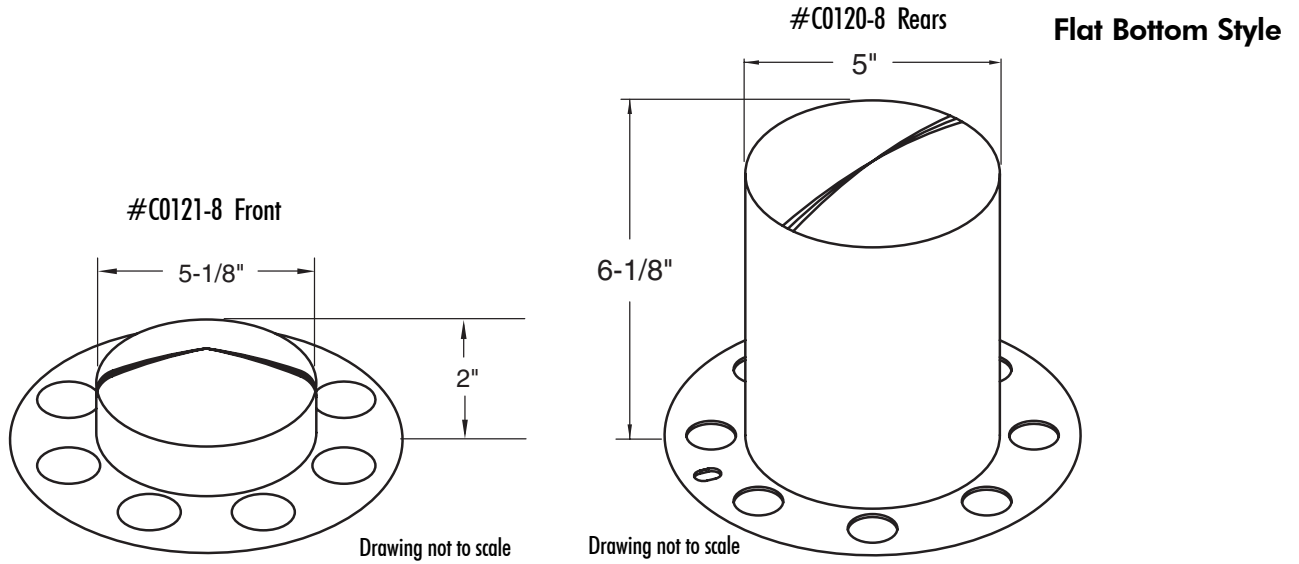

DESCRIPTION	PART#	PRICE EA.
8 Lug Fronts		
Chrome - Flat Bottom Style	C0121-8*	\$3.99 each
Stainless - Flat Bottom Style	C0121-8-S*	\$5.99 each
8 Lug Rears		
Chrome - Flat Bottom Style	C0120-8*	\$6.99 each
Stainless - Flat Bottom Style	C0120-8-S*	\$14.99 each

*Available by special order only.
Call for details.

ALUMINUM CENTER CAP

DESCRIPTION	PART#	PRICE EA.
5 Eared Aluminum Center Cap Plain face/no logo (Includes screws and hex wrench)	PWA-99-0286	\$19.99 each

Reproduction of Original TT wheel 5 Ear polished Aluminum Center Cap

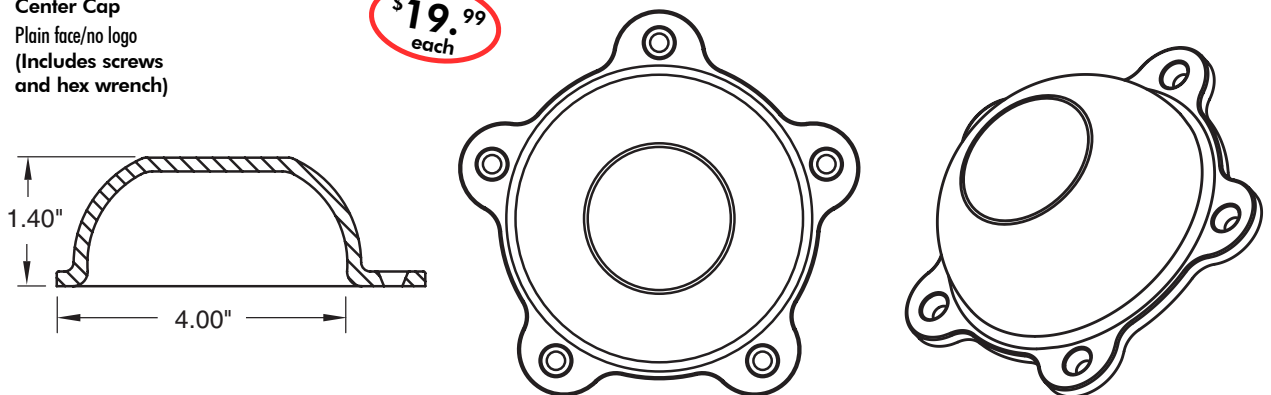

PLASTIC POP IN HUB CAPS

Small Gear Cap, Black

HEIGHT	BORE	PART#
1-1/4"	2.52"	1326

\$1.99
each

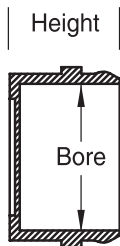

Drawing not to scale

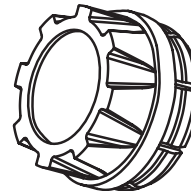
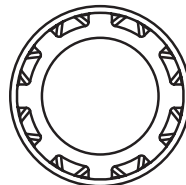

Small Bullet Pop-In, Chromed 2.750" Bore

Drawing not to scale

#1302

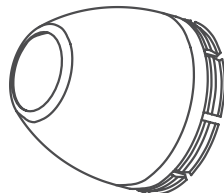
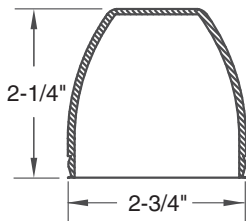

\$2.99
each

Medium Bullet Pop-In, Chromed 3.225" Bore

Drawing not to scale

#1303

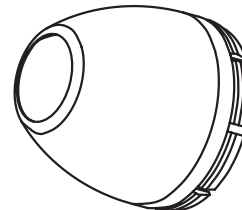
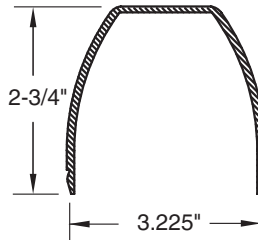

\$2.99
each

5 Ear Universal Cap, Chromed

Drawing not to scale

5 Ear #1332

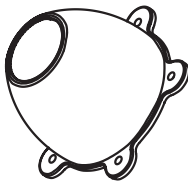
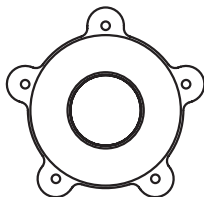
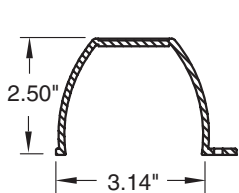

\$3.49
each

Push-Thru, Chromed 3.50" Bore

Drawing not to scale

#PWA-89-8021-P

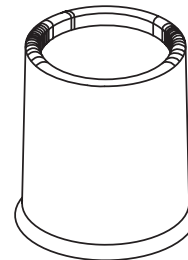
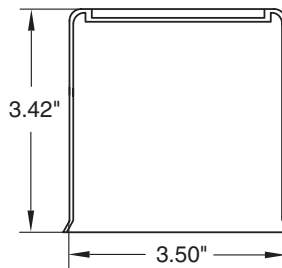

\$2.99
each

CAPS

CHROME POP IN CAPS FOR AFTERMARKET WHEELS

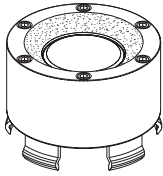

These two caps are interchangeable - Flat face or Dome face.

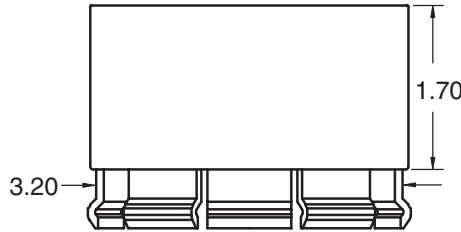

\$3.99 each

PART#	HEIGHT	BORE	LOGO RECESS DIM
PWA-99-0162	1.70"	3.20"	1.70" O.D.

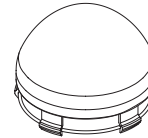

Drawings not to scale

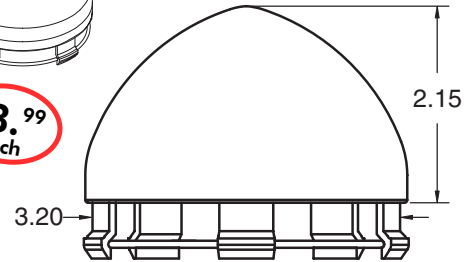

\$3.99 each

PART#	HEIGHT	BORE	LOGO RECESS DIM
PWA-99-9997	2-5/32"	3.20"	domed cap

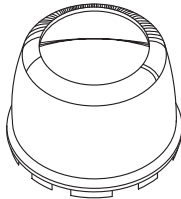

Drawings not to scale

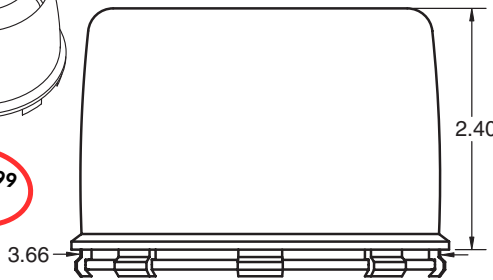

\$3.99 each

PART#	HEIGHT	BORE	LOGO RECESS DIM
PWA-99-7253	2-3/4"	3-2/3"(93mm)	1/16"

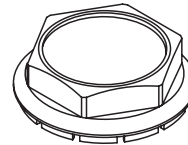

Drawings not to scale

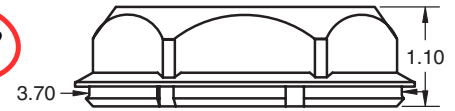

\$2.99 each

PART#	HEIGHT	BORE	LOGO RECESS
PWA-99-5001	3/4"	3-5/8"(3.7/94mm)	.230 Deep

These two caps are interchangeable - Flat face or Dome face.

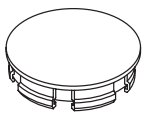

Drawings not to scale

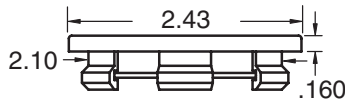

\$1.99 each

PART#	HEIGHT	BORE	LOGO RECESS DIM
PWA-99-10373-C	.160"	2.10"	smooth flat cap

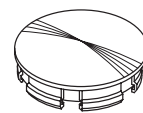

Drawings not to scale

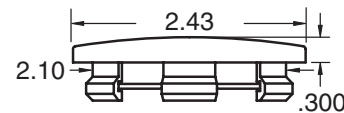

\$1.99 each

PART#	HEIGHT	BORE	LOGO RECESS DIM
PWA-99-10373-CD	.300"	2.10"	domed cap

CAPS

CHROME PLASTIC CAPS

For use on popular CT 8 Style wheels
CT 9 Style wheels
CT 10 Style wheels

These wheels were sold under various names and style numbers by :

- Progressive
- Prime
- Superior
- Unique
- U.S. Wheel
- And many others

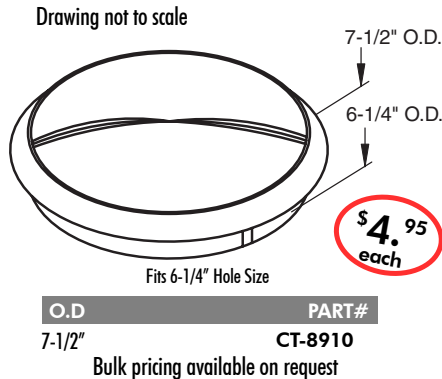

CHROME COVERED LUG NUT STYLE CAP

Non-Skirted with Lock Hole

These wheels were sold under various names and style numbers by :

- American Racing
- AMTECH
- CCI
- MHT
- DNA
- Elite
- Ultra
- Vogue
- Epic

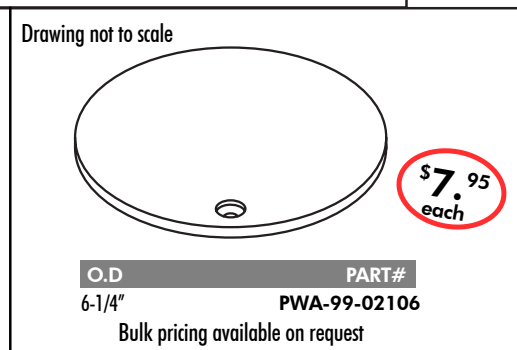
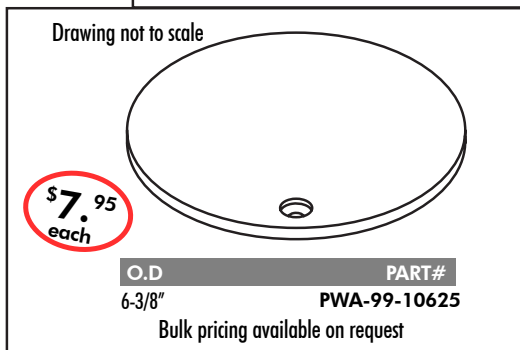
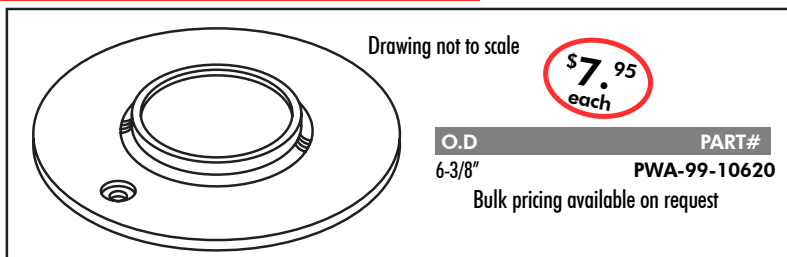

POP-IN ANODIZED "TUNER" CAPS

Matte black plastic base and hex nut with anodized aluminum cover (3 colors to choose from).

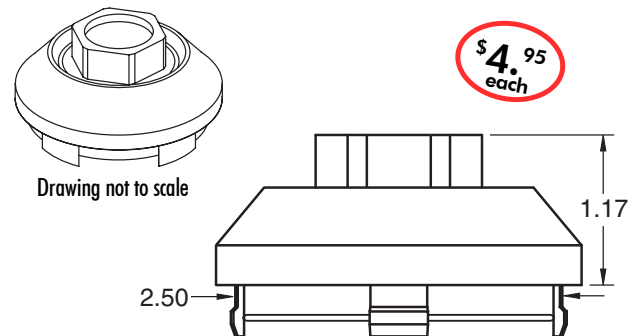

PART#	HEIGHT	BORE	LOGO RECESS
PWA-89-9117-R (Red)	1.17"	2.50"	.20"
PWA-89-9117-B (Blue)	1.17"	2.50"	.20"
PWA-89-9117-S (Silver)	1.17"	2.50"	.20"

Matte black plastic base w/o hex nut with silver aluminum cover (Flat recessed area to accept 1-3/4" Dia. lens).

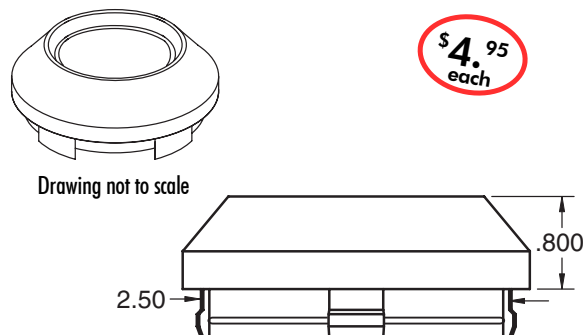

PART#	HEIGHT	BORE	LOGO RECESS
PWA-89-9117-S-RP (Silver)	.800"	2.50"	.20"

CAPS

CHROME PLASTIC CAPS

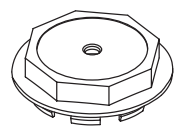

Drawings not to scale

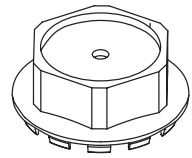

Drawings not to scale

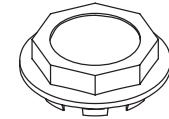

Drawings not to scale

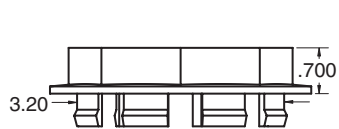

O.D. PART#
3.20" SDW00133

Bulk pricing available on request

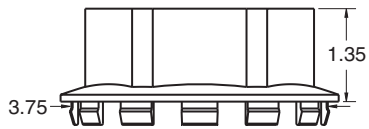

O.D. PART#
3.75" SDW00228

Bulk pricing available on request

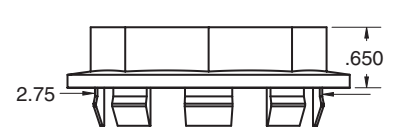

O.D. PART#
2.75" 1050-0100

Bulk pricing available on request

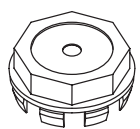

Drawings not to scale

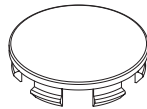

Drawings not to scale

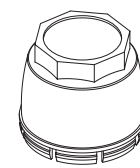

Drawings not to scale

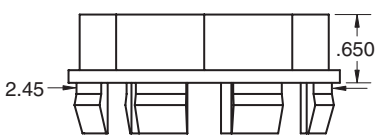

O.D. PART#
2.45" 1050-0119

Bulk pricing available on request

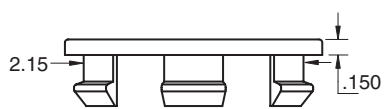

O.D. PART#
2.15" DW00232

Bulk pricing available on request

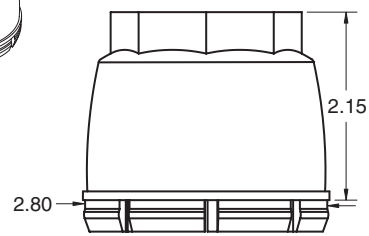

O.D. PART#
2.80" S1050-113

Bulk pricing available on request

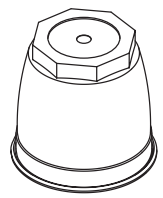

Drawings not to scale

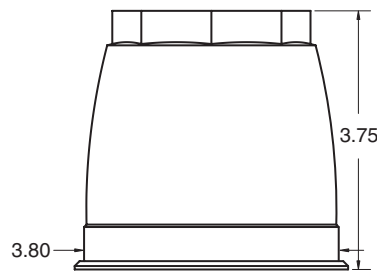

O.D. PART#
3.80" SDW00141

Bulk pricing available on request

**ANY CAP
ON THIS
PAGE**

**\$1.99
each**

- All sales final
- No returns
- Blow out liquidation

RIVETS

PLASTIC WHEEL RIVETS

Chrome or Gold Plated Plastic Rivet

SIZE	COLOR	PART#
Short Shank	Chrome	PWA-RC-119-S
Short Shank	Gold	PWA-RG-119-S
Long Shank	Chrome	PWA-RC-119
Long Shank	Gold	PWA-RG-119

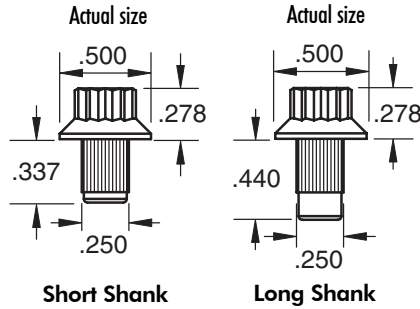
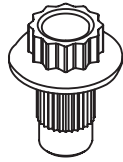

CHROME

.22^c
each
Bag of 100

.15^c
each
Quantity of 1000

GOLD

Bag of 100

Quantity of 1000

.29^c
each

.20^c
each

Chrome Plated Plastic Simulated Socket Head Rivet

SIZE	PART#
.350 O.D.	PWA-RC-0233-350
.450 O.D.	PWA-RC-0186-450
.550 O.D.	PWA-RC-0181-550
.650 O.D.	PWA-RC-0398-650

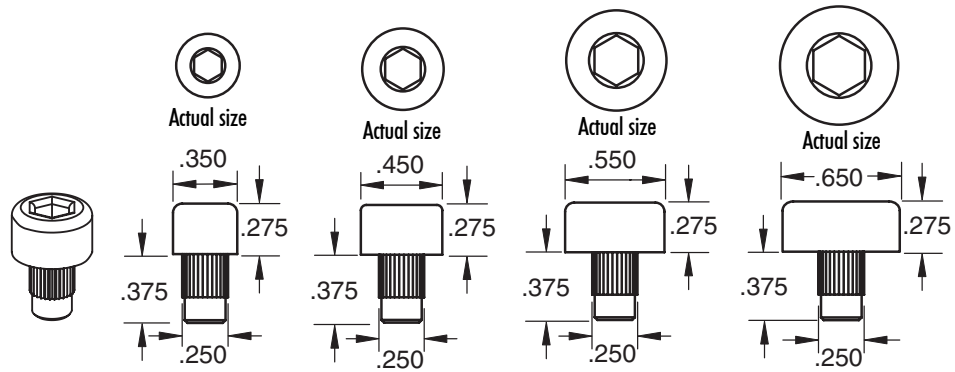

CHROME

.22^c
each
Bag of 100

.15^c
each
Quantity of 1000

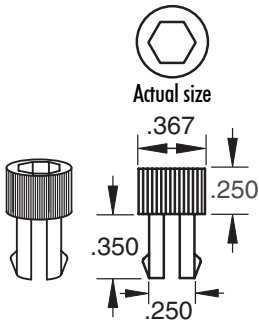

Chrome Plated Plastic Simulated Socket Head Rivet w/ Split Shank

SIZE	PART#
.366 O.D.	PWA-RC-0001-366

CHROME

.12^c
each
Bag of 100

.09^c
each
Quantity of 1000

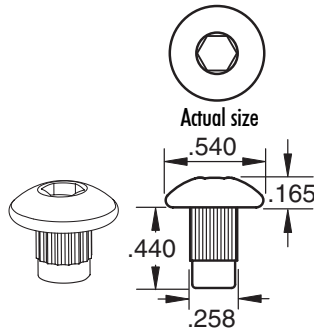

Chrome Plated Plastic Simulated Button Head Rivet

SIZE	PART#
.540 O.D.	PWA-RC-0354-540

CHROME

.22^c
each
Bag of 100

.15^c
each
Quantity of 1000

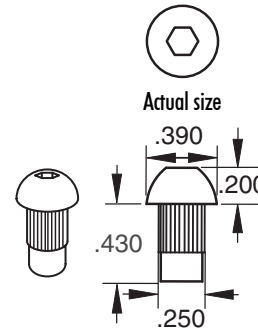

Plastic Simulated Socket Button Head Rivet

SIZE	COLOR	PART#
.390 O.D.	Black	PWA-RB-106
.390 O.D.	Chrome	PWA-RC-106

BLACK

.13^c
each
Bag of 100

CHROME

.07^c
each
Quantity of 1000

.21^c
each
Bag of 100

.14^c
each
Quantity of 1000

RIVETS

ALUMINUM WHEEL RIVETS

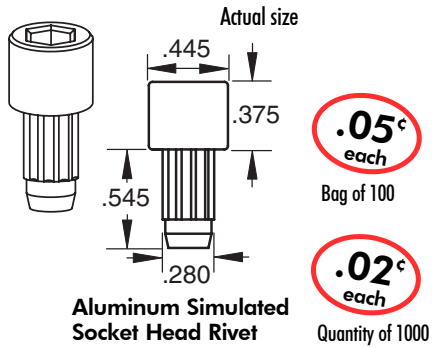

Aluminum Simulated Socket Head Rivet
Quantity of 1000

SIZE	PART#
.445 O.D.	PWA-RS-0020-450
.445 O.D. (Gold)	PWA-RG-0020-450

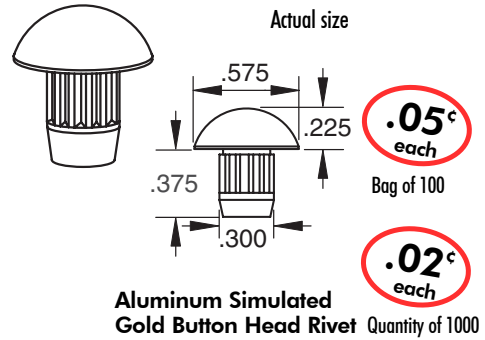

Aluminum Simulated Gold Button Head Rivet
Quantity of 1000

SIZE	PART#
.575 O.D. (Gold)	PWA-RG-0030-575

WHEEL ASSEMBLY BOLTS

Grade 8

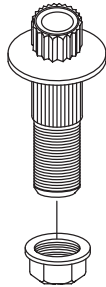

Wheel Assembly Bolts for 2 and 3 piece wheels.

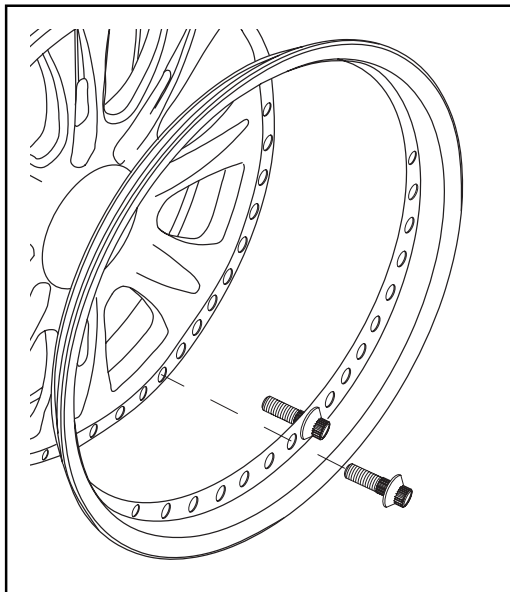

Head Flange Max O.D. :	.610
Spline O.D. :	.330
Shank Length :	1.180
Thread Size :	5/16 x 24

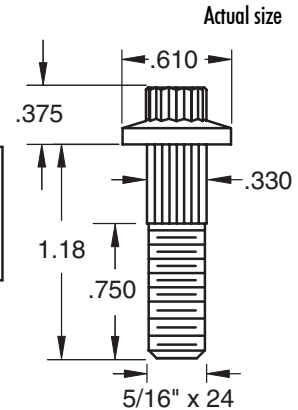

Chrome Plated 12pt Stainless Steel Bolt

SIZE	PART#
5/16" X 24	PWA-99-0028

.56¢
each
Bag of 100

.40¢
each
Quantity of 1000

.10¢
each
Bag of 100

.08¢
each
Quantity of 1000

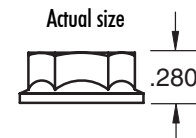

Chrome Plated 5/16" Flange Nut

SIZE	PART#
5/16"	PWA-99-0031

CAP LOCKS

HUB CAP LOCKS

Chrome Plated Finish supplied in sets of four with key in poly bag with attractive header card. Master packs of 10 sets.

.480 Small Head Taper Seat - 8mm x 1.25 thread

PART#	THREAD	LENGTH
500-800-100	8mm x 1.25	1.00"
500-800-275	8mm x 1.25	2.75"
500-99-9950	Key Only	

\$3.99
Per set of 4

.89¢
each

HEAD TYPE TOP VIEW

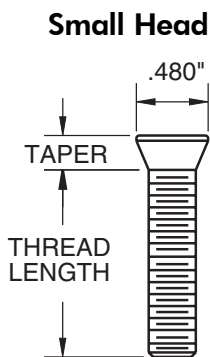

KEY Part #500-99-9950

HEAD TYPE

Drawing not to scale

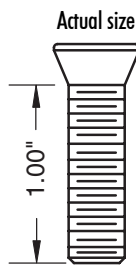

500-800-100

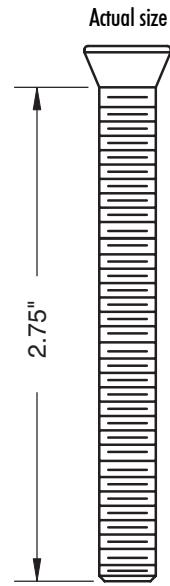

500-800-275

.480 Small Head Multi-Fit - 8mm x 1.25 thread

PART#	THREAD	LENGTH
550-800-100	8mm x 1.25	1.00"
550-800-125	8mm x 1.25	1.25"
550-800-150	8mm x 1.25	1.50"
550-800-175	8mm x 1.25	1.75"
550-800-200	8mm x 1.25	2.00"
500-99-9950	Key Only	

\$3.99
Per set of 4

Flat seat style cap

Cone seat style cap

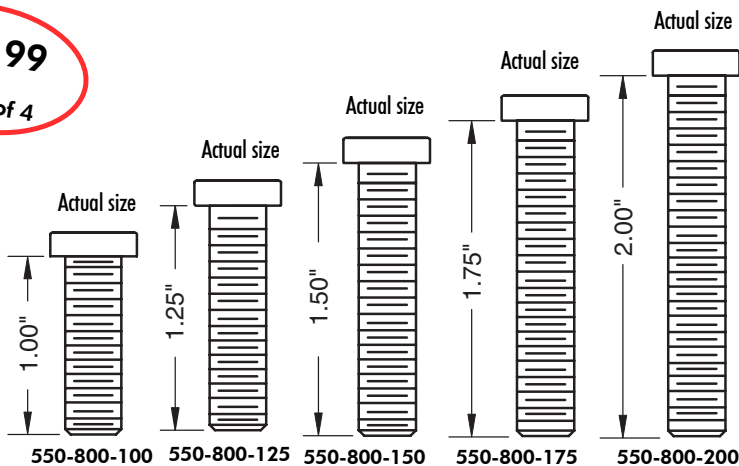
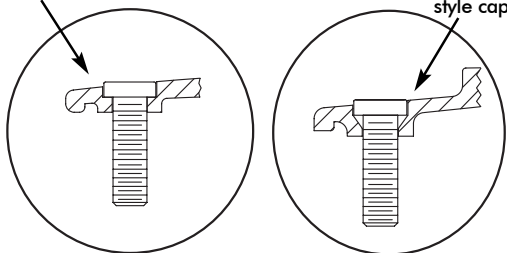

This new Multi-Fit style head design allows you to use the same lock on caps with a cone seat or flat seat lock hole.

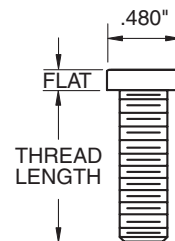

CAP LOCKS

HUB CAP LOCKS

.620 Large Head Flat Seat - 8mm x 1.25 thread

Chrome Plated Finish supplied in sets of four with key in poly bag with attractive header card. Master packs of 10 sets.

PART#	THREAD	LENGTH
650-800-075	8mm x 1.25	0.75"
600-99-0309	Key Only	

Additional key available for only .89¢ Large Head

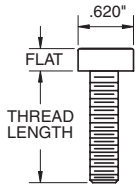

HEAD TYPE TOP VIEW

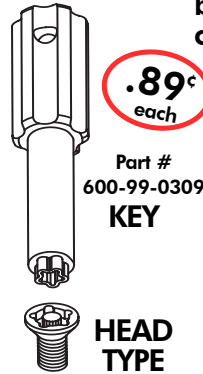

Drawing not to scale

\$3.99
Per set of 4

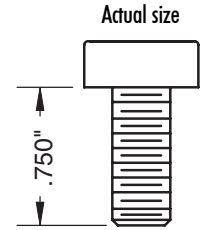

650-800-075

.620 Large Head Taper Seat - 5/16" thread

PART#	THREAD	LENGTH
600-516-075	5/16"	0.75"
600-516-100	5/16"	1.00"
600-516-125	5/16"	1.25"
600-516-200	5/16"	2.00"
600-99-0309	Key Only	

Additional key available for only .89¢

\$3.99
Per set of 4

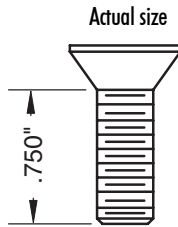

600-516-075

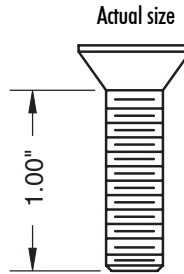

600-516-100

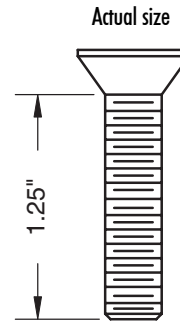

600-516-125

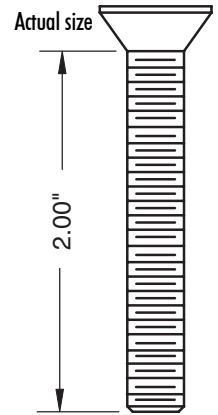

600-516-200

.620 Large Head Taper Seat - 8mm x 1.25 thread

PART#	THREAD	LENGTH
600-800-063	8mm x 1.25	0.63"
600-800-225	8mm x 1.25	2.25"
600-800-240	8mm x 1.25	2.40"
600-800-275	8mm x 1.25	2.75"
600-800-325	8mm x 1.25	3.25"
600-99-0309	Key Only	

Additional key available for only .89¢

\$3.99
Per set of 4

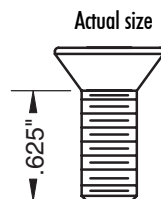

600-800-063

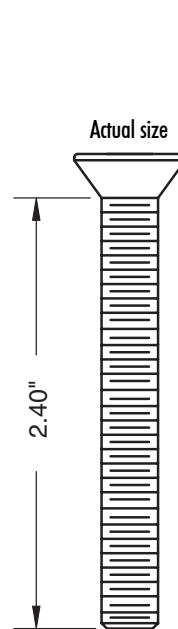

600-800-240

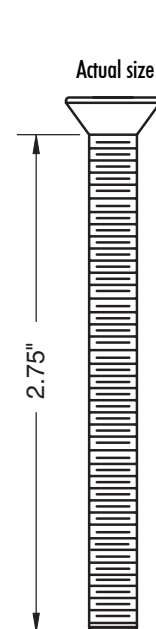

600-800-275

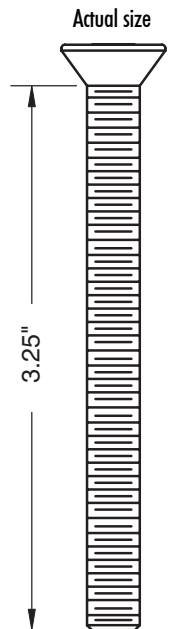

600-800-325

CAPS FOR O.E.M. CHROME WHEELS

Chrome plastic caps to fit O.E.M. Alloy Wheels

Replaces the stock plastic cap on chromed wheels.

The Prestige Wheel Accessories Chrome Center Caps listed in this catalog are specifically designed for use on O.E.M. alloy wheels that have been chrome plated.

The caps described in this application guide are not actual factory parts and should never be sold or represented as actual O.E.M. products.

Most Prestige center caps have a smooth chrome plated face with no provisions for locating or mounting logos or badges.

However, some Prestige center caps are available with locating holes or grooves to facilitate the transfer and installation of O.E.M. emblems which have been removed from the original factory caps.

Prestige Wheel Accessories has developed several of its own design stylized logos, however we do not offer any reproductions of trademarked O.E.M. logos.

Prestige Wheel Accessories DOES NOT offer any reproductions of trademarked original equipment logos for sale.

www.oemchromecaps.com

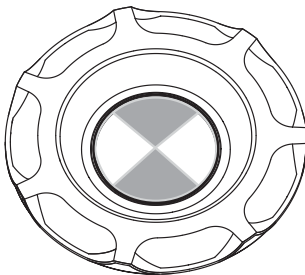
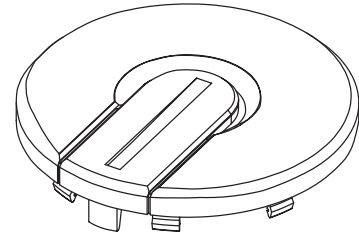
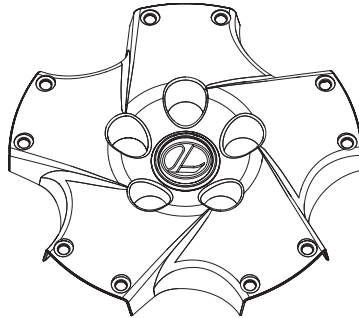
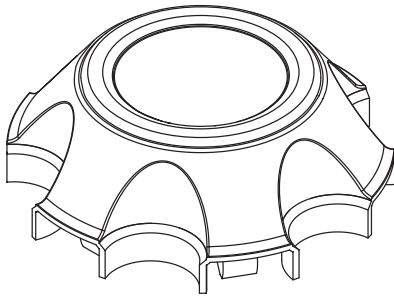

Because of constant information changes. Call for supplemental cap guide.

Call for Details!

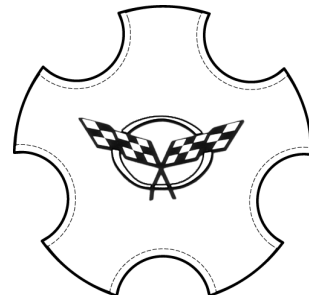
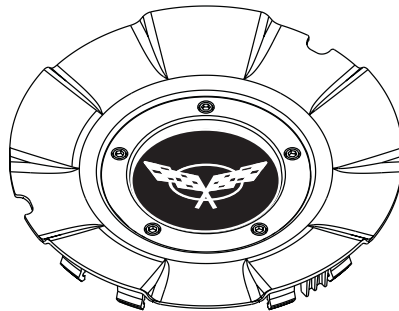
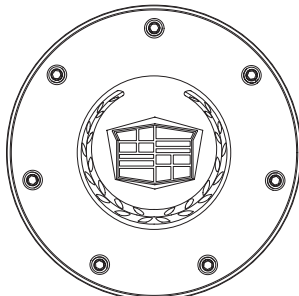
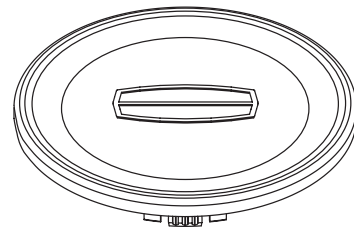

Prestige
WHEEL ACCESSORIES

(800) 854-6770 (877) LUG-NUTS

(714) 841-6333

Fax: (714) 841-6413

5 8 4 - 6 8 8 7

M-F 7:30AM - 4:30PM CALIF TIME

REFERENCE GUIDE

CAPS FOR O.E.M. CHROME WHEELS

ACURA

2.2 CL
2.3 CL
2.5 TL
3.0 CL
3.2 TL/CL
3.2 TL/CL TYPE S
3.5 RL
INTEGRA
INTEGRA TYPE "R"
LEGEND
MDX (SUV)
NSX
RSX

BMW

MINI COOPER
325i
525i
530i
535i
540i
635CSi
735i
740i
750i
M6

BUICK

RIVIERA

CADILLAC

CTS
CONCOURS
DEVILLE SEDAN
ELDORADO
ESCALADE
SEVILLE
STS

CHEVROLET (CARS)

CAMARO
CAMARO (Z28 "SS")
CORVETTE ZR1
CORVETTE
CORVETTE Z06
CORVETTE CAP KIT
IMPALA
LUMINA
MALIBU
MONTE CARLO

CHEVROLET TRUCKS/

VANS & SUV's)

1500 & 2500 VANS
ASTRO VANS
AVALANCHE
BLAZER (4X4)
CHEVY & GMC (4X2)/(4X4)
HUMMMER H2
SILVERADO
& 1500 SERIES
GMC 10 & 20
SERIES VANS
SAFARI
SIERRA C3/DENALI
SUBURBAN
SS
TAHOE (2X4)/(4X4)
DENALI
YUKON
EXTREME OPTION
(S-10 & S-15 SONOMA)
EXTREME BLAZER
TRAIL BLAZER
ENVOY
BLAZER & S15 JIMMY

CHRYSLER

SEBRING
SEBRING (CONVERT)

DODGE

DAKOTA
DAKOTA-RT
DURANGO

FORD

CONTOUR

ESCAPE
EXPEDITION
EXPLORER
FOCUS
LIGHTNING "SVT"
MUSTANG
MUSTANG GT
MUST. "SVT"/COBRA
TAURUS
TAURUS "GL"
T-BIRD "LX" SPORT PKG
T-BIRD "LX"

HONDA

ACCORD
SE model only
ACCORD
except station wagon
Coupe EX V6
ODYSSEY
PRELUDE
S 2000 ROADSTER

INFINITI

I 30
I 35
Q 45
Q 45
QX4
G 35

JAGUAR

XJ6
XJ6
XJ8 & VDP

JEEP

CHEROKEE
GRAND CH. LAREDO
CHEROKEE LTD
GRAND CHEROKEE
GRAND WAGONEER
WRANGLER
LIBERTY

LEXUS

ES 250
ES 300
GS 300
GS 400
GS 430
IS 300
LS 400/(COACH)
LS 430
SC 430
LX 450
LX 470
RX 300
SC SERIES
IS 300 SPORTCROSS

LINCOLN

BLACKWOOD/NAV.
NAVIGATOR
LINCOLN/TOWN CAR
LS 2000
LS 4 DOOR SEDAN
TOWNCAR/LIMO.

MAZDA

929
MIATA
MILLENNIA

MERCEDES BENZ

All MODELS

MERCURY

COUGAR
COUGAR
MYSTIQUE
SABLE
VILLAGER

MITSUBISHI

3000GT
DIAMANTE
ECLIPSE
ECLIPSE SPYDER
GALLANT
MONTERO LTD
SPIDER

NISSAN

240 ZX
300 ZX
350 Z
ALTIMA
FRONTIER
MAXIMA
MAXIMA GIE/SE
PATHFINDER
SENTRA
XTERRA

OLDSMOBILE

AURORA
AURORA (V-8)

ROVER

FREELANDER
DISCOVERY
LAND ROVER/
DISCOVERY
RANGE ROVER

TOYOTA

4 RUNNER
AVALON
CAMRY
CAMRY "LE"
COROLLA
HIGHLANDER
LAND CRUISER
RAV-4
SIENNA
SEQUOIA
SEQUOIA LIMITED
SOLARA
TACOMA
TUNDRA

VOLKSWAGEN

EUROVAN
JETTA
NEW BEETLE
PASSAT

**New caps
added weekly.
Please Call
for details.**

www.oemchromecaps.com

Prestige
WHEEL ACCESSORIES

(800) 854-6770 (877) LUG-NUTS

(714) 841-6333

Fax: (714) 841-6413

5 8 4 - 6 8 8 7

M-F 7:30AM - 4:30PM CALIF TIME

PORSCHE LUG NUTS

Aluminum Extra Light O.E. Style for Porsche Style Alloy Wheels

Most Popular Model

19MM ALUMINUM

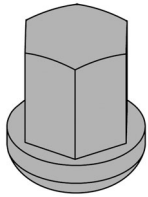

Drawings not to scale

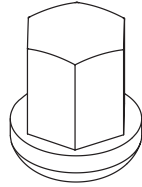

Drawings not to scale

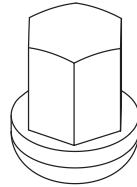

Drawings not to scale

FINISH	SIZE	PART#	FINISH	SIZE	PART#	FINISH	SIZE	PART#
Black	14mm 1.50	POR-5172	Polished	14mm 1.50	POR-5174	Chromed	14mm 1.50	POR-5176

\$7.50
each

\$8.50
each

\$8.99
each

19MM STEEL

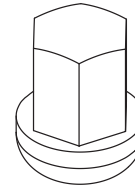

Drawings not to scale

FINISH	SIZE	PART#
Chromed Steel	14mm 1.50	POR-5188

\$2.99
each

SOFT SOCKET LUG WRENCH

Drawings not to scale

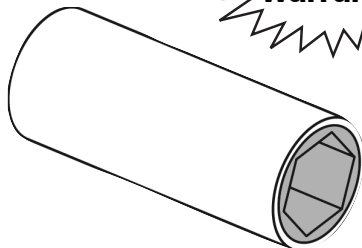

Lifetime Warranty

For Porsche alloy lug nuts. Won't mar expensive lug nuts because of the special socket liner.

- **Patented Light Weight Design**
Sockets incorporate an exterior casing made of hardend steel filled with an *Ultra Hard Fiberglass Core*.
- **Exceeds Industry Standard Torque Recommendations**
(Max 200 ft lbs of Torque)
- **Protects Surrounding Surfaces**
Fiberglass core protrudes out from steel casing so that the face of the socket will not harm surrounding surfaces.

DESCRIPTION	PART#	NET PRICE
19mm Soft Socket (1/2" Drive)	POR-1900SS	\$24.95 each

GEAR STYLE WHEEL LOCKS

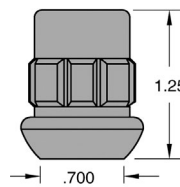

Drawings not to scale

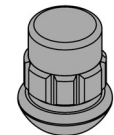
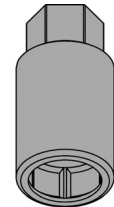

These gear style locks are designed for the Porsche enthusiast who needs the light weight of aluminum. The set of 4 locks includes a socket.

Available in black only.

FINISH	SIZE	PART#	NET PRICE
Black	14mm 1.50	POR-77641	\$29.95 set

PORSCHE LUG NUT COVERS



Drawings not to scale

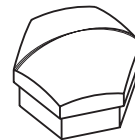

Chrome or Black

FINISH	SIZE	PART#
Chromed	19mm	99-9999-C
Black	19mm	99-9999-B

These covers fit all Porsche lug nuts or bolts with 19mm hex head.

Dress up any exposed lug installation with these covers. Packaged in sets of 20 with removal tool.



.69¢
each

TOOLS & SALES AIDS

No matter how good a product is, top sales ultimately depend on an attractive and functional display.

Using our Tools & Sales Aids will not only impress customers with your professionalism, it will boost sales at the same time!

Prestige Wheel Accessories offers an extensive line of tool and sale aids the will:

- Increase customer interest
- Organize product
- Boost overall sales with add-ons
- Identify thread pitch and bolt circles
- Make products easily identified as samples get attention!

HUB RING STORAGE KIT

Part# HR100



You pick the mix that best fits your needs.

Purchase 30 sets (120 rings) at \$1.75 per ring and we will include a **FREE** compartmentalized storage box with your order.

Your total purchase price is = \$210.⁰⁰
(120 rings x \$1.75)

Bin with 32 compartments comes with a clear plastic lid that we will custom label with the part numbers you choose.

This allows for easy re-ordering.

Hub ring storage box with dividers and lid sold without rings \$48.99

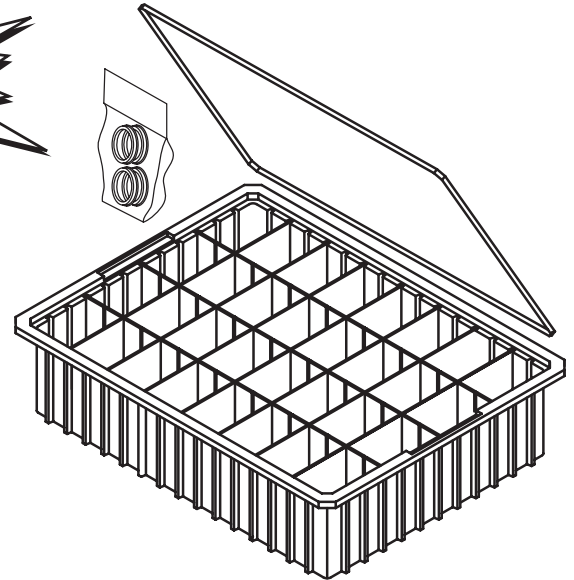

AKRO PLASTIC PARTS BINS

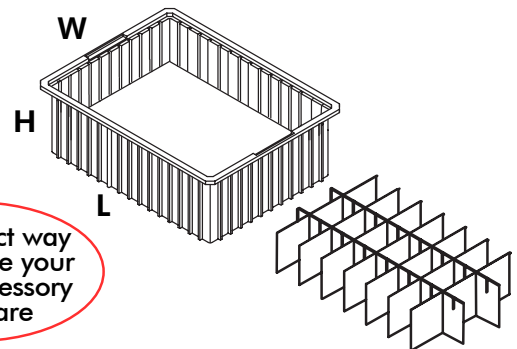
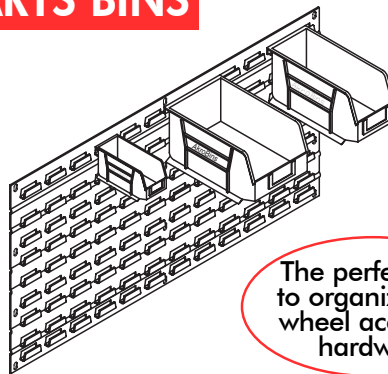
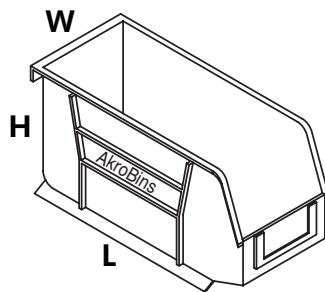

DESCRIPTION	SIZES			PART#	NET PRICE
	L	W	H		
Small Bin	L 5-3/8" x	W 4-1/8" x	H 3"	30-210	1.25 Each
Medium Bin	L 10-7/8" x	W 5-1/2" x	H 5"	30-230	3.99 Each
Large Bin	L 10-3/4" x	W 8-1/4" x	H 7"	30-239	6.99 Each
Metal Wall Rack	L 35-3/4"	x	H 19"	30-636	36.50 Each
Lid for Large Clear (33-228) Grid Box				43-946	11.95 Each
Large Grid Box	L 22" x	W 17" x	H 8"	33-228	15.99 Each
Grid Dividers - short	L 15-1/2"			41-228	2.00 Each
Grid Dividers - long	L 20-1/2"			42-228	2.25 Each

TOOLS & SALES AIDS

LUG WRENCH ADAPTERS

These handy lug wrench adapters are just what you need...

when custom wheels are installed and you want to retain the stock lug wrench that came with the vehicle.

Match up the male end to the original lug wrench and the female end to the new lug size.

You and your customer will be glad you went the extra mile when they have to change a flat tire.

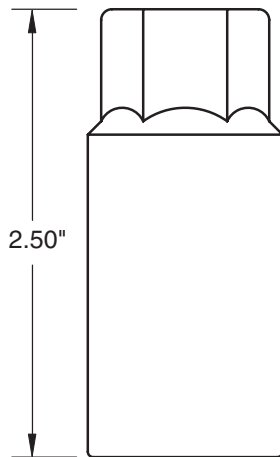

Actual size

2.²⁹
each

PART#	FROM (Lug Wrench)	TO (Lug Nut)
	MALE END (fits into lug wrench)	FEMALE END (goes over nut)
LWA-025*	3/4" (19mm)	3/4" (19mm)
LWA-050*	13/16" (21mm)	3/4" (19mm)
LWA-150*	3/4" (19mm)	13/16" (21mm)
LWA-200*	13/16" (21mm)	13/16" (21mm)
LWA-300*	7/8"	13/16" (21mm)
LWA-400*	7/8"	7/8"

*Not for use with impact wrench

MULTI-SIZE LUG WRENCH ADAPTERS

We offer these multi-size lug wrench adapters for extra convenience in your shop!

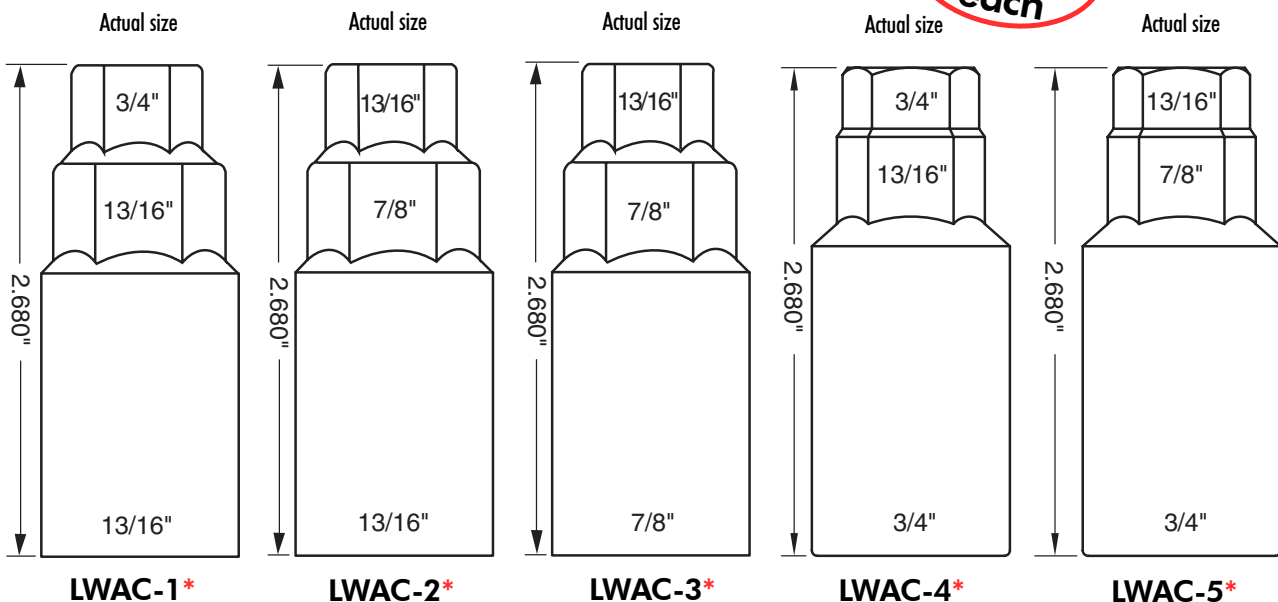

\$2.⁷⁹
each

*Not for use with impact wrench

TOOLS & SALES AIDS

LUG WRENCH-

Extended

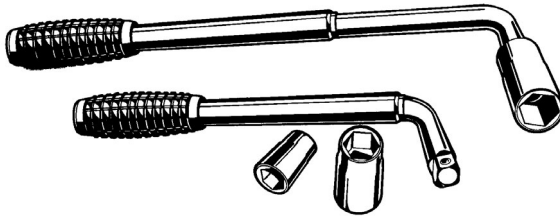

14" TELESCOPING POWER WRENCH - with telescoping handle that extends to 22" providing the extra leverage needed for removing even the tightest lug nuts.

Made of hardened steel and built to last.
Supplied with 2 sockets.

DESCRIPTION	PART#
14" TELESCOPING POWER WRENCH	PLWC410

Includes 2 Sockets (3/4" & 13/16")

9.95
each

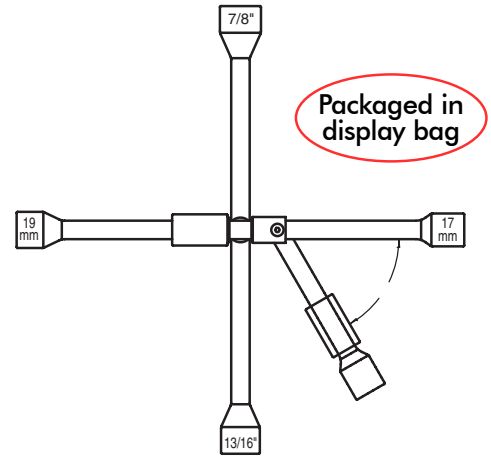

DESCRIPTION	PART#
FOLDING 4-WAY - Socket end sizes:	FLW2805

17mm
3/4" (19mm)
13/16" (21mm)
7/8"

6.95
each

WHEEL DISPLAY ITEMS

Stick-on Wheel Weights

Sold by the box. Standard pack 9 lbs.

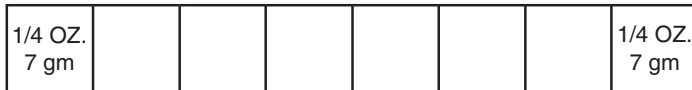

DESCRIPTION	STD. PACK	PART#
Stick-on, Silver	Box/9 lbs.	WW-200624

\$21.00
each

2 Box master pack	2 box case/18 lbs.	WW-200624-2PK
-------------------	--------------------	---------------

\$39.95
each

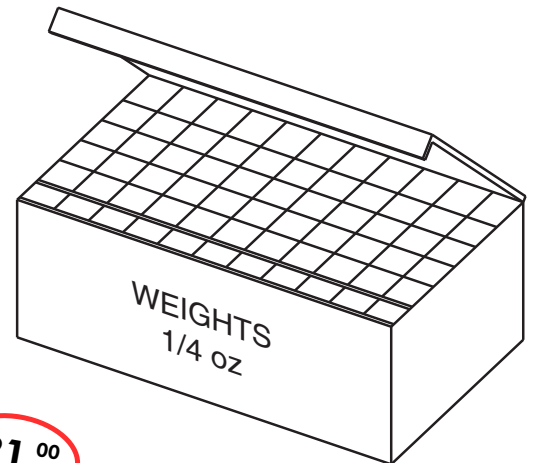

TOOLS & SALES AIDS

MEASURING TOOLS

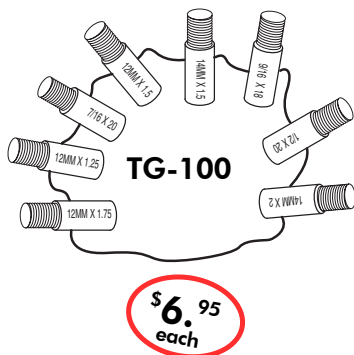

\$6.95
each

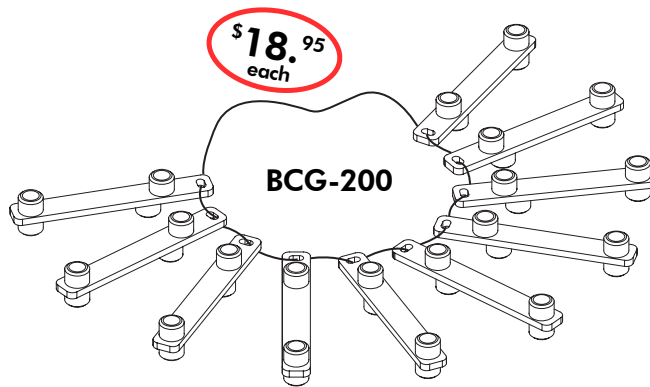

\$18.95
each

BCG-200
measures the following:

4-LUG **5-LUG**

4 x 98mm	5 x 100mm
4 x 100mm	5 x 112mm
4 x 110mm	5 x 115mm
4 x 120mm	5 x 130mm
4 x 130mm	5 x 4"
4 x 140mm	5 x 4-1/4"
4 x 3-3/4"	5 x 4-1/2"
4 x 4"	5 x 4-3/4"
4 x 4-1/4"	5 x 5"
4 x 4-1/2"	5 x 5-1/2"

DESCRIPTION	PART#	STD. PACK	NET PRICE
Thread Size Check Gauges	TG-100	Set	6.95
Bolt Circle Gauge	BCG-200	Set	18.95

CALIPER BOLT CIRCLE GAUGE

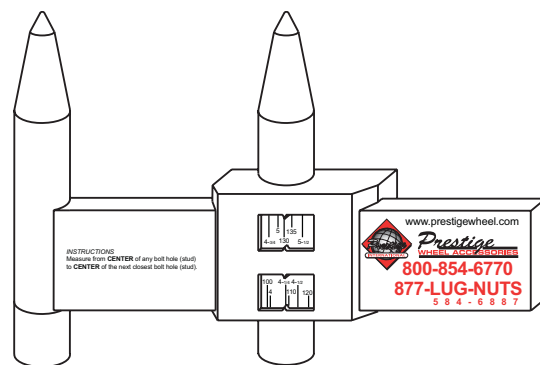
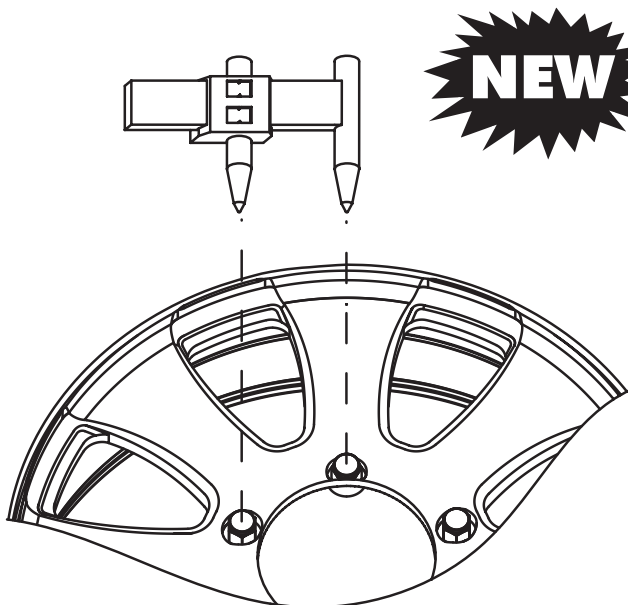

DESCRIPTION	PART#
CALIPER BOLT CIRCLE GAUGE	BCG-300
Measures most popular 4,5,6 & 8 lug bolt circles	

12.95
each

Prestige
WHEEL ACCESSORIES

(800) 854-6770 (877) LUG-NUTS

(714) 841-6333

Fax: (714) 841-6413

5 8 4 - 6 8 8 7

M-F 7:30AM - 4:30PM CALIF TIME

WHEEL DISPLAY ITEMS

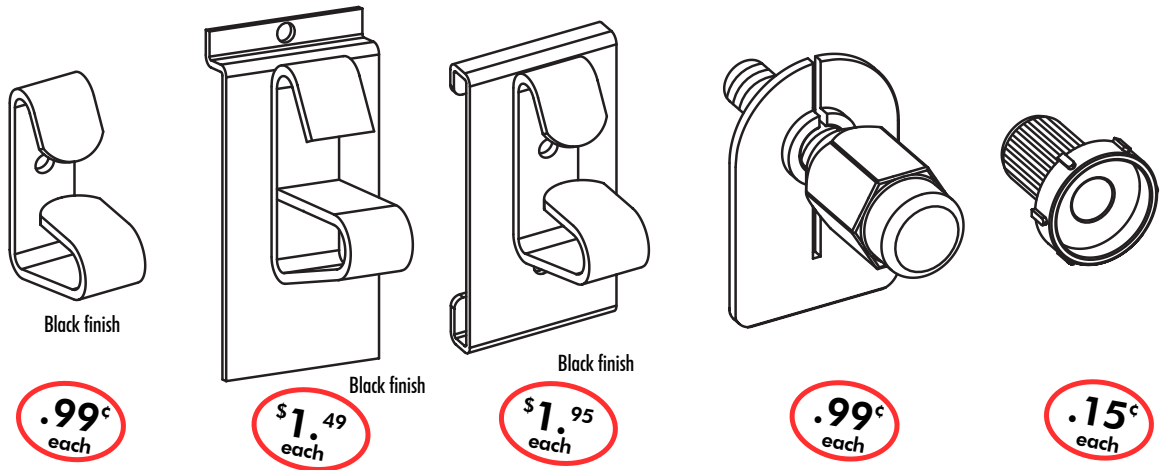

DESCRIPTION	PART#	STD. SELL	CASE QTY	NET PRICE
Metal Wheel Display Hook	MWDH-100	Each	50	.99
Slat-wall Wheel Display Hook	SLWH-200	Each	50	1.49
Grid-wall Wheel Display Hook	GRWH-300	Each	50	1.49
Chrome Display Lug Nut w/backing	DLN-041	Each	100	.99
Display Wheel Lug Plug*	LPG-100	100	100	.15

*Fits 1/2" Lug Nuts Only

LUG PLUGS / EMBLEMS

PLASTIC LUG HOLE PLUGS

Aftermarket wheels are often drilled with 8 or 10 holes to fit different bolt patterns. Now you can fill the holes that are not used with these colorful plugs to get a finished look.

These are very popular in the "Tuner" and small truck markets.

Drawing not to scale

PART#	DESCRIPTION
PWA-99-9825-C	Chrome finish
PWA-99-9825-B	Blue Anodized finish
PWA-99-9825-R	Red Anodized finish

Packaged in Bags of 100 **.69¢ each**

SOFT POLY PRESTIGE LENSES

.99¢ each

Acrylic lens with Black Background with Chrome Stylized Lettering

PART#	SIZE
88-8010	1.75" O.D.
88-8012	2.25" O.D.
88-8014	3" O.D.

SOFT POLY EAGLE LENSES

Diameter 2-3/4"

1.49 each

-or-

.99¢ each when purchasing 100 of same color

Drawing not to scale

PART#	DESCRIPTION
88-5551	Black background w/ Gold Eagle
88-5552	White Background w/ Gold Eagle
88-5554	Red Background w/ Gold Eagle
88-5556	Blue Background w/ Gold Eagle

TOOLS & SALES AIDS

WHEEL RACKS

Displaying your wheels in an attractive and safe manner is important to your business success.

These specially designed wheel racks are the standard in the industry and are frequently used by the wheel manufacturers at the various trade shows.

5 minute assembly and disassembly as well as durability and modularity are some of the noted features of these redesigned racks.

These racks are boxed to ship via U.P.S.

Dimensions:
23 W x 70 1/2 H x 23 D

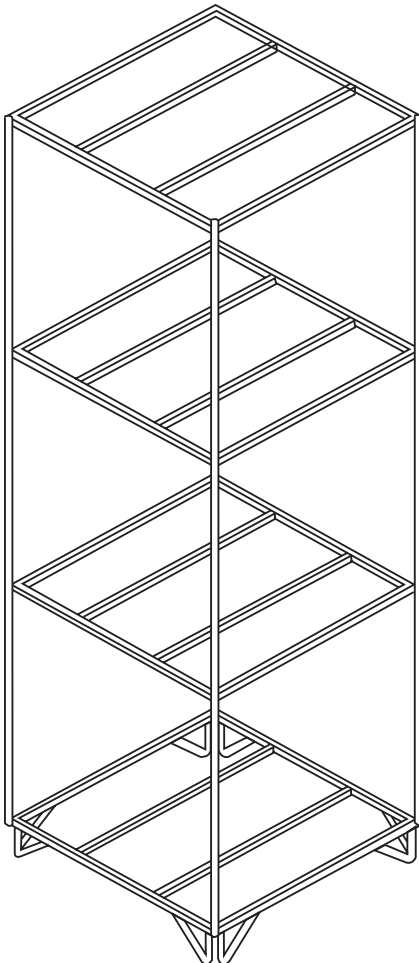

**New Design
and Sizes**

3 Cube Wheel Display Rack accepts up to 20" Wheels
Black or Chrome finish Available
(8 Wheels maximum)

- ◆ Fits 8 Wheels maximum
- ◆ Chrome or Black finish
- ◆ 5 minute assembly
- ◆ Fits up to 20" Wheels
- ◆ Redesigned for Increased Sturdiness

Part

WR-B-20 (Black)

Order 1-9

\$69.95
each

Order 10+

\$59.95
each

WR-C-20 (Chrome)

Order 1-9

\$69.95
each

Order 10+

\$59.95
each

Prestige
WHEEL ACCESSORIES

(800) 854-6770 (877) LUG-NUTS

(714) 841-6333

5 8 4 - 6 8 8 7

Fax: (714) 841-6413

M-F 7:30AM - 4:30PM CALIF TIME

TOOLS & SALES AIDS

2 Cube Wheel Display Rack accepts up to 24" Wheels
 Black or Chrome finish Available
 (6 Wheels maximum)

- ◆ Fits 6 Wheels maximum
- ◆ Chrome or Black finish
- ◆ 5 minute assembly
- ◆ Fits up to 24" Wheels
- ◆ Redesigned for Increased Sturdiness

Dimensions:
 27 1/2 W x 56 1/2 H x 27 1/2 D

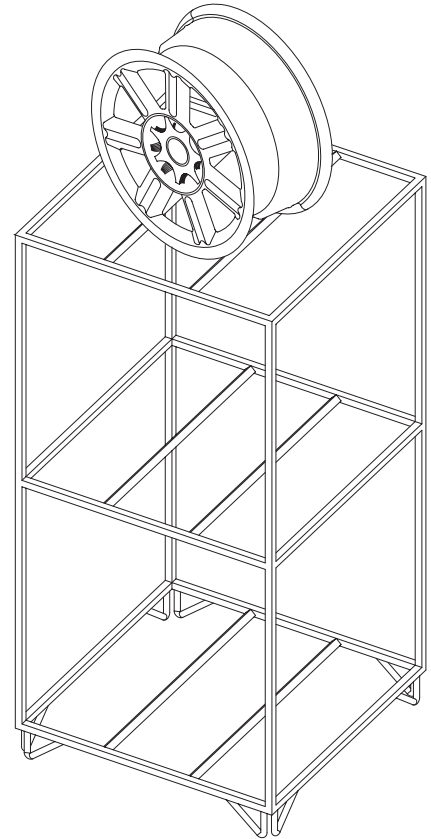

Part

WR-B-24 (Black)

Order 1-9

\$69.95
each

Order 10+

\$59.95
each

WR-C-24 (Chrome)

Order 1-9

\$69.95
each

Order 10+

\$59.95
each

DISPLAY WHEEL BACK COVERS

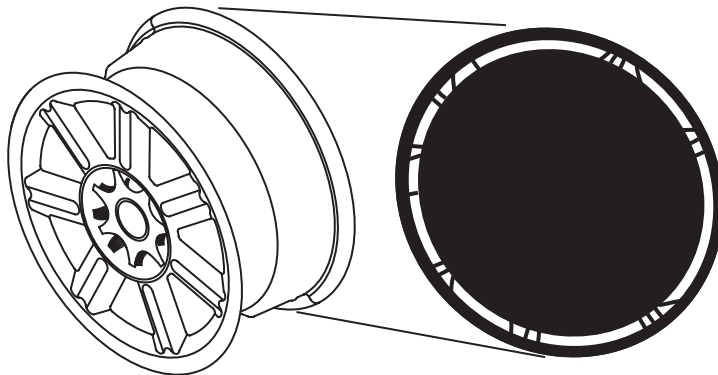

Front side of Wheel Cover



*Call for Details

Washable Cloth Display Wheel Back Covers for backside of display wheels.(Color Black)

Part #
PWA-99-9951-17

Fits Wheel Size
 Up to 17" Wheel **\$1.99**

PWA-99-9951-22

18" to 22" Wheel **\$1.99**

RESALE CERTIFICATE

SALES TAX RULES/REGULATIONS

TO OUR CUSTOMERS:

In compliance with Sales and Use Tax Laws it is necessary that we have from ALL of our customers a signed resale certificate, with their State Sales Tax number, to show that the merchandise has been purchased for resale.

The good faith of the seller will be questioned if he has knowledge of facts which give rise to a reasonable inference that the purchaser does not intend to resell the property as, for example, knowledge that purchaser of particular merchandise is not engaged in the business of selling that kind of merchandise.

Under "Description of property to be purchased" there may appear:

1) Either an itemized list of the particular property to be purchased for resale
- OR -

2) A general description of the kind of property to be purchased for resale

Such certificate is good until revoked in writing.

Please make a photocopy of this page, fill out the resale certificate below with your sales tax permit number, signature and address, then return it to:

Prestige Wheel Accessories
16892 D Gothard Street
Huntington Beach, CA 92647

Or fax it to us at:
(714) 841-6413

RESALE CERTIFICATE

 (Name of purchaser)

 (Address of purchaser)

I hereby certify that I hold valid seller's permit number _____
 issued pursuant to the Sales Tax and Use Law; that I am engaged in the business of selling

CUSTOM WHEELS OR ACCESSORY ITEMS

that the tangible personal property described herein which I shall purchase from:

HIDK Inc, dba Prestige Wheel Accessories

will be resold by me in the form of tangible personal property; provided, however, that in the event any of such property is used for any purpose other than retention, demonstration, or display while holding it for sale in the regular course of business, it is understood that I am required by Sales and Use Tax Law to report and pay tax, measured by the purchase price of such property.

Description of property to be purchased:

 Date

()

 Phone

 Printed name of Purchaser/Authorized Agent and Title

 Signature of Purchaser/Authorized Agent

CONVERSION CHART

MEASUREMENT EQUIVALENTS

Fractions	Inches	Millimeters
1/64	.015625	.397
1/32	.03125	.794
3/64	.046875	1.191
1/16	.0625	1.588
5/64	.078125	1.984
3/32	.09375	2.381
7/64	.109375	2.778
1/8	.125	3.175
9/64	.140625	3.572
5/32	.15625	3.969
11/64	.171875	4.366
3/16	.1875	4.762
13/64	.203125	5.159
7/32	.21875	5.556
15/64	.234375	5.953
1/4	.250	6.350
17/64	.265625	6.747
9/32	.28125	7.144
19/64	.296875	7.541
5/16	.3125	7.938
21/64	.328125	8.334
11/32	.34375	8.731
23/64	.359375	9.128
3/8	.375	9.525
25/64	.390625	9.922
13/32	.40625	10.319
27/64	.421875	10.716
7/16	.4375	11.112
9/64	.453125	11.509
15/32	.46875	11.906
31/64	.484375	12.303
1/2	.500	12.700

Fractions	Inches	Millimeters
33/64	.515625	13.097
17/32	.53125	13.494
35/64	.546875	13.891
9/16	.5625	14.288
37/64	.578125	14.684
19/32	.59375	15.081
39/64	.609375	15.478
5/8	.625	15.875
41/64	.640625	16.272
21/32	.65625	16.669
43/64	.671875	17.066
11/16	.6875	17.462
45/64	.703125	17.859
23/32	.71875	18.256
47/64	.734375	18.653
3/4	.750	19.050
49/64	.765625	19.447
25/32	.78125	19.844
51/64	.796875	20.241
13/16	.8125	20.638
53/64	.828125	21.034
27/32	.84375	21.431
55/64	.859375	21.828
7/8	.875	22.225
57/64	.890625	22.622
29/32	.90625	23.019
59/64	.921875	23.416
15/16	.9375	23.812
61/64	.953125	24.209
31/32	.96875	24.606
63/64	.984375	25.003
1	1.000	25.400

HUB CENTRIC RINGS

HUB CENTRIC WHEELS AND HUB CENTRIC RINGS

WHAT IS THIS ALL ABOUT ?

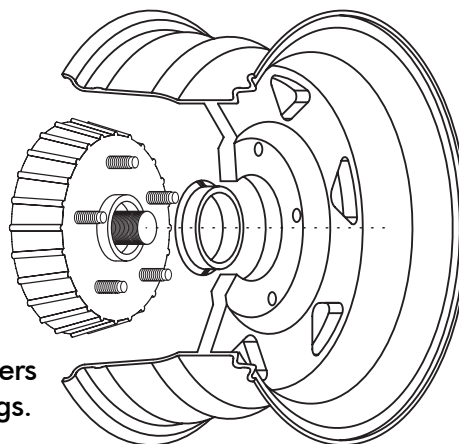

We thought you might like to know what various manufacturers and tire dealers are asking about hub centric wheels and rings.

Q: *Exactly, what does hub centric mean?*

A: Hub centric wheels are manufactured so that when they are installed on a vehicle, the wheels are located directly off of the center flange of the brake drum or rotor.

This is done to insure that the outer beads of the wheel are concentric with the wheel bearings. The result is a much truer, better balanced tire/wheel assembly. This is very important with modern hightech suspension systems.

Q: *What about the phrase "Lug Centric"? Isn't it just as good?*

A: NO! Lug centric is a marketing phrase made up by the few manufacturers who don't offer hub centric wheels. Their theory is that if the wheels are drilled for conical seat lug nuts, then the wheels will self locate.

Surveys have shown that most installers just hang the wheel/tire combination on the studs and put on the lug nuts expecting the angle of the conical seat to pull the wheel/tire combination into concentricity.

Recent tests by several major wheel manufacturers have shown that when the above mentioned mis-locating occurs the studs actually bend down slightly thus creating an artificial out-of-round condition by as much as .0025

Consequently the custom wheel often gets a bad rap because of a poor installation job. Hub centric wheels or hub centric rings will correct this situation.

Q: *OK! I'm convinced that hub centric location is the way to go, so why not just use wheels that are already machined hub centric?*

Why bother with hub centric rings?

A: **INVENTORY FLEXIBILITY.**

Wheels drilled in a 4 x 100 bolt pattern fit 23 different brand name cars, but require 7 different bore sizes.

Wheels drilled in a 4 x 4.50 bolt pattern fit 12 different brand name cars, but require 6 different bore sizes.

Wheels drilled in a 5 x 100 bolt pattern fit 12 different brand name cars, but require 4 different bore sizes.

Wheels drilled in a 5 x 4.50 bolt pattern fit 20 different brand name cars, but require 9 different bore sizes.

By Stocking wheels that are machined hub centric to a specific bore size, it would require that you stock **26 different wheel part numbers** in each different wheel rim diameter size to get the coverage of these 67 applications.

If you use wheels which are machined for use with hub centric rings, you can get the same coverage with only **4 wheel part numbers.**

Q: *Which ring should I use, those hi-tech looking aluminum rings or the composite Polycarbonate plastic?*

A: While aluminum rings look Hi-Tech, they actually are not as good as the composite Polycarbonate plastic rings.

The drum or rotor snout of most vehicles are made of cast iron, so when a raw aluminum ring is placed directly against it and even a small amount of moisture gets in, corrosion occurs almost immediately, making it very difficult to get the wheel off of the car.

The composite Polycarbonate material acts like an "O"-ring, eliminating this common problem.

Q: *What hub ring sizes are available for various wheels and bores?*

A: Application information is provided on the following pages.

Prestige
WHEEL ACCESSORIES

(800) 854-6770 (877) LUG-NUTS

(714) 841-6333

5 8 4 - 6 8 8 7

Fax: (714) 841-6413

M-F 7:30AM - 4:30PM CALIF TIME

HUB CENTRIC RINGS

PLEASE READ THIS FIRST!

When dealing with hub-centric rings it is important to visualize that a hub-centric ring is basically a reducer bushing.

These hub rings are designed to reduce the aftermarket wheel bore size from its current size to the O.E. bore size of the car you are trying to fit.

As manufacturers often make changes in their production system, we cannot absolutely guarantee the information we have provided on the following pages.

The information provided was collected from various dependable sources within the tire and wheel industry along with information supplied by O.E automobile manufacturers when possible.

This information is provided as a general guideline and should never be taken as absolute fact. When in doubt, you, the installer or user, must verify all information on the application in question.

Our policy on hub ring orders is as follows:

It is your responsibility to choose the correct ring for your particular application. Should the hub rings you choose prove to be inadequate for your needs, Prestige Wheel Accessories is under no obligation to take them back.

You purchased them, you own them.

THINGS TO CONSIDER

Manufacturers do make running changes during a model year and sometimes these changes affect wheel and tire sizes or attachment hardware.

Most automobile manufacturers offer some models with optional wheel and or tire combinations.

When in doubt check the specific vehicle in question.

Automobile manufacturers sometimes offer some special limited edition models with special wheel and or tire combination.

When in doubt check the specific vehicle in.

Sometimes automobile manufacturers make the same model vehicle in more than one factory location. We have seen cases where vehicles made in different factories use different wheel and tire combinations or attachment hardware.

When in doubt check the specific vehicle in question.

How to correctly order hub centric rings:

- STEP 1** Determine the center bore size of the aftermarket wheel you plan to install.
- STEP 2** Look up the vehicle you are trying to fit in the application information guide on pages #70 - #81.
- STEP 3** After finding the correct vehicle, note the "wheel I.D. hub bore" of that vehicle.
- STEP 4** Now with...the O.D. (the bore size of the aftermarket wheel) And... the I.D. (the O.E. locating flange size of the vehicle)
- Turn to our "hub ring list" on page #68 - #69 to find the part number you need.
- STEP 5** Call us toll free at 1-800-854-6770 and place your order.

REMEMBER... you need to know the following facts to order the right hub centric ring:

1. From: the aftermarket wheel information

manufacturer _____

center bore size _____

2. To: the vehicle information

year _____

make _____

model _____

hub locating flange size _____

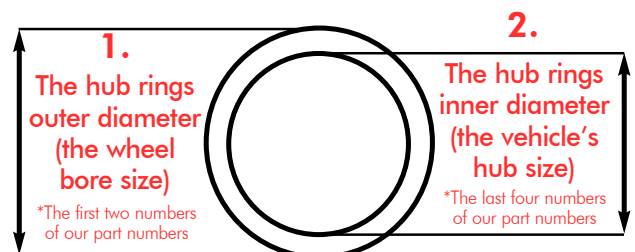

HUB CENTRIC RINGS

HUB CENTRIC RINGS PART LIST

MOST CARS

INNER BORE SIZE	PART#
OUTSIDE DIAMETER 60.00mm/2.359"	
54.06 Inner Bore	HR60-5406
56.15 Inner Bore	HR60-5615
57.10 Inner Bore	HR60-5710
OUTSIDE DIAMETER 66.06mm/2.600"	
54.06 Inner Bore	HR66-5406
56.15 Inner Bore	HR66-5615
57.10 Inner Bore	HR66-5710
59.20 Inner Bore	HR66-5920*
59.61 Inner Bore	HR66-5961*
60.06 Inner Bore	HR66-6006
63.36 Inner Bore	HR66-6336*
63.90 Inner Bore	HR66-6390
64.15 Inner Bore	HR66-6415
OUTSIDE DIAMETER 67mm/2.683"	
54.06 Inner Bore	HR67-5406
56.15 Inner Bore	HR67-5615
57.10 Inner Bore	HR67-5710
59.20 Inner Bore	HR67-5920
60.06 Inner Bore	HR67-6006
64.15 Inner Bore	HR67-6415
OUTSIDE DIAMETER 68.00mm/2.677"	
67.10 Inner Bore	HR68-6710*
OUTSIDE DIAMETER 69.85mm/2.750"	
54.06 Inner Bore	HR69-5406*
56.15 Inner Bore	HR69-5615*
57.10 Inner Bore	HR69-5710
59.20 Inner Bore	HR69-5920*
59.61 Inner Bore	HR69-5961*
60.06 Inner Bore	HR69-6006*
63.36 Inner Bore	HR69-6336*
63.90 Inner Bore	HR69-6390*
64.15 Inner Bore	HR69-6415*
65.07 Inner Bore	HR69-6507*
66.06 Inner Bore	HR69-6606*
66.56 Inner Bore	HR69-6656*
67.10 Inner Bore	HR69-6710
OUTSIDE DIAMETER 70mm/2.755"	
54.06 Inner Bore	HR70-5406*
56.15 Inner Bore	HR70-5615
57.10 Inner Bore	HR70-5710
59.20 Inner Bore	HR70-5920*
59.61 Inner Bore	HR70-5961*
60.06 Inner Bore	HR70-6006
63.36 Inner Bore	HR70-6336*
63.90 Inner Bore	HR70-6390*
64.15 Inner Bore	HR70-6415*
65.07 Inner Bore	HR70-6507*
60.06 Inner Bore	HR70-6006*
66.06 Inner Bore	HR70-6606*
66.56 Inner Bore	HR70-6656*
67.10 Inner Bore	HR70-6710*

* Due to low volume this item may not be in stock. We are happy to machine to order these items for you.
All custom machine to order items require **5-10** business days lead time.
Contact sales department for details.

INNER BORE SIZE	PART#
OUTSIDE DIAMETER 71.12mm/2.800"	
54.06 Inner Bore	HR71-5406
56.15 Inner Bore	HR71-5615
57.10 Inner Bore	HR71-5710
59.20 Inner Bore	HR71-5920*
59.61 Inner Bore	HR71-5961*
60.06 Inner Bore	HR71-6006
63.36 Inner Bore	HR71-6336
63.90 Inner Bore	HR71-6390*
64.15 Inner Bore	HR71-6415*
65.07 Inner Bore	HR71-6507*
66.06 Inner Bore	HR71-6606*
66.56 Inner Bore	HR71-6656*
67.10 Inner Bore	HR71-6710*
70.10 Inner Bore	HR71-7010*
OUTSIDE DIAMETER 72.62mm/2.859"	
54.06 Inner Bore	HR72-5406
56.15 Inner Bore	HR72-5615
57.10 Inner Bore	HR72-5710
59.20 Inner Bore	HR72-5920
59.61 Inner Bore	HR72-5961
60.06 Inner Bore	HR72-6006
63.36 Inner Bore	HR72-6336
63.90 Inner Bore	HR72-6390
64.15 Inner Bore	HR72-6415
65.07 Inner Bore	HR72-6507
66.06 Inner Bore	HR72-6606
66.56 Inner Bore	HR72-6656
67.10 Inner Bore	HR72-6710
70.10 Inner Bore	HR72-7010
70.30 Inner Bore	HR72-7030
70.50 Inner Bore	HR72-7050
OUTSIDE DIAMETER 73.00mm/2.870"	
54.06 Inner Bore	HR73-5406
56.15 Inner Bore	HR73-5615
57.10 Inner Bore	HR73-5710
59.20 Inner Bore	HR73-5920
59.61 Inner Bore	HR73-5961
60.06 Inner Bore	HR73-6006
63.36 Inner Bore	HR73-6336
63.90 Inner Bore	HR73-6390
64.15 Inner Bore	HR73-6415
65.07 Inner Bore	HR73-6507
66.06 Inner Bore	HR73-6606
66.56 Inner Bore	HR73-6656
67.10 Inner Bore	HR73-6710
70.10 Inner Bore	HR73-7010
70.30 Inner Bore	HR73-7030
70.50 Inner Bore	HR73-7050
71.50 Inner Bore	HR73-7150

All Hubrings Priced Ea. Packaged in Sets of 4

Quantity	Price per Ring (Most O.D.)
1-39 pcs.	\$2.50 ea. Hub Ring
40 pcs.	\$2.25 ea. Hub Ring
80 pcs.	\$2.00 ea. Hub Ring
120 pcs.	\$1.75 ea. Hub Ring
500 pcs.	\$1.50 ea. Hub Ring
1000pcs.	\$1.25 ea. Hub Ring

Bulk made to order prices available for orders above 1000 pcs.
Contact sales department for details.

INNER BORE SIZE	PART#
OUTSIDE DIAMETER 74.00mm/2.913"	
54.06 Inner Bore	HR74-5406
56.15 Inner Bore	HR74-5615*
57.10 Inner Bore	HR74-5710*
59.20 Inner Bore	HR74-5920*
59.61 Inner Bore	HR74-5961*
60.06 Inner Bore	HR74-6006
63.36 Inner Bore	HR74-6336*
63.90 Inner Bore	HR74-6390*
64.15 Inner Bore	HR74-6415*
65.07 Inner Bore	HR74-6507*
66.06 Inner Bore	HR74-6606
66.56 Inner Bore	HR74-6656
67.10 Inner Bore	HR74-6710
70.10 Inner Bore	HR74-7010
70.30 Inner Bore	HR74-7030*
70.50 Inner Bore	HR74-7050
71.50 Inner Bore	HR74-7150*
72.56 Inner Bore	HR74-7256
OUTSIDE DIAMETER 75.00mm/2.950"	
54.06 Inner Bore	HR75-5406*
56.15 Inner Bore	HR75-5615*
57.10 Inner Bore	HR75-5710*
59.20 Inner Bore	HR75-5920*
59.61 Inner Bore	HR75-5961*
60.06 Inner Bore	HR75-6006*
63.36 Inner Bore	HR75-6336*
63.90 Inner Bore	HR75-6390*
64.15 Inner Bore	HR75-6415*
65.07 Inner Bore	HR75-6507*
66.06 Inner Bore	HR75-6606*
66.56 Inner Bore	HR75-6656*
67.10 Inner Bore	HR75-6710*
67.30 Inner Bore	HR75-6730*
70.10 Inner Bore	HR75-7010
70.30 Inner Bore	HR75-7030
70.50 Inner Bore	HR75-7050*
71.50 Inner Bore	HR75-7150*
72.56 Inner Bore	HR75-7256*
OUTSIDE DIAMETER 76.00mm/2.992"	
54.06 Inner Bore	HR76-5406*
56.15 Inner Bore	HR76-5615
57.10 Inner Bore	HR76-5710
59.20 Inner Bore	HR76-5920*
59.61 Inner Bore	HR76-5961*
60.06 Inner Bore	HR76-6006
63.36 Inner Bore	HR76-6336*
63.90 Inner Bore	HR76-6390*
64.15 Inner Bore	HR76-6415
65.07 Inner Bore	HR76-6507*
66.06 Inner Bore	HR76-6606
66.56 Inner Bore	HR76-6656*
67.10 Inner Bore	HR76-6710
70.10 Inner Bore	HR76-7010*
70.30 Inner Bore	HR76-7030
70.50 Inner Bore	HR76-7050
71.50 Inner Bore	HR76-7150
72.56 Inner Bore	HR76-7256

HUB CENTRIC RINGS

HUB CENTRIC RINGS PART LIST

MOST TRUCKS/SUV

INNER BORE SIZE	PART#
OUTSIDE DIAMETER 87.00mm/3.425" 78.03 Inner Bore	HR87-7803
OUTSIDE DIAMETER 105.00mm/4.133" 78.03 Inner Bore	HR105-7803*
OUTSIDE DIAMETER 108.00mm/4.250" 78.03 Inner Bore 106.00 Inner Bore	HR108-7803 HR108-106
OUTSIDE DIAMETER 110.00mm/4.330" 78.03 Inner Bore	HR110-7803

ADDITIONAL HELPFUL INFORMATION

78.03 MM = LATE GM 6 LUG
87.00 MM = LATE FORD
106.00 MM = MITSUBISHI
108.00 MM = LATE DODGE
110.00 MM = TOYOTA

* Due to low volume this item may not be in stock. We are happy to machine to order these items for you.
All custom machine to order items require **5-10 business days lead time.**
Contact sales department for details.

All Hubrings Priced Ea. Packaged in Sets of 4

Quantity	Price per Ring (Truck/Large O.D.)
1-39 pcs.	\$3.95 ea. Hub Ring
40 pcs.	\$3.50 ea. Hub Ring
80 pcs.	\$3.00 ea. Hub Ring
120 pcs.	\$2.60 ea. Hub Ring
500 pcs.	\$2.20 ea. Hub Ring
1000pcs.	\$1.80 ea. Hub Ring

Bulk made to order prices available for orders above 1000 pcs.
Contact sales department for details.

MOST DUALY

INNER BORE SIZE	PART#
OUTSIDE DIAMETER 125.00mm/4.920" 116.7 Inner Bore 121.3 Inner Bore	HR125-116 HR125-121
OUTSIDE DIAMETER 130.00mm/5.150" 116.7 Inner Bore 121.3 Inner Bore 124.9 Inner Bore	HR130-116 HR130-121 HR130-124

ADDITIONAL HELPFUL INFORMATION

116.00 MM = GM 8 LUG
121.30 MM = DODGE 8 LUG
124.90 MM = LATE FORD 8 LUG
HUMMER 8 LUG

* Due to low volume this item may not be in stock. We are happy to machine to order these items for you.
All custom machine to order items require **5-10 business days lead time.**
Contact sales department for details.

All Hubrings Priced Ea. Packaged in Sets of 4

Quantity	Price per Ring (Truck/Large O.D.)
1-39 pcs.	\$3.95 ea. Hub Ring
40 pcs.	\$3.50 ea. Hub Ring
80 pcs.	\$3.00 ea. Hub Ring
120 pcs.	\$2.60 ea. Hub Ring
500 pcs.	\$2.20 ea. Hub Ring
1000pcs.	\$1.80 ea. Hub Ring

Bulk made to order prices available for orders above 1000 pcs.
Contact sales department for details.

HUB RING STORAGE KIT

Part# HR100

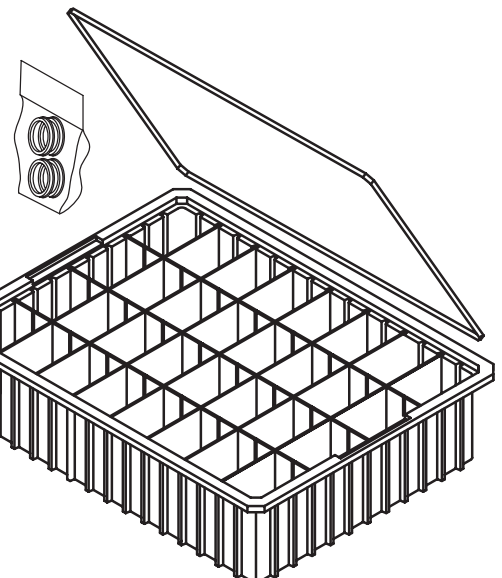

You pick the mix that best fits your needs.

Purchase 30 sets (120 rings) at \$1.75 per ring and we will include a **FREE** compartmentalized storage box with your order.

Your total purchase price is = \$210.00
(120 rings x \$1.75)

Bin with 32 compartments comes with a clear plastic lid that we will custom label with the part numbers you choose.

This allows for easy re-ordering.

Hub ring storage box with dividers and lid sold without rings \$48.99

APPLICATION GUIDE

CAR APPLICATION GUIDE

MAKE/MODEL	YEAR	BOLT CIRCLE	HUB BORE	LUG SIZE	LUG TYPE	NOTES
ACURA						
Integra	96-on	4 X 100	MM	56.15 MM	12 MM X 1.50 R.H.	NUT
RSX	02-on	5 X 114.3	MM	64.15 MM	12 MM X 1.50 R.H.	NUT
2.2 / 3.0 CL / S-TYPE	96-on	4 X 114.3	MM	64.15 MM	12 MM X 1.50 R.H.	NUT
2.5 TL	95-on	4 X 114.3	MM	64.15 MM	12 MM X 1.50 R.H.	NUT
Legend	86-91	4 X 114.3	MM	64.15 MM	12 MM X 1.50 R.H.	NUT
Vigor	93-99	4 X 114.3	MM	64.15 MM	12 MM X 1.50 R.H.	NUT
RL 3.5	96-on	5 X 114.3	MM	64.15 MM	12 MM X 1.50 R.H.	NUT
TL 3.2	95-on	5 X 114.3	MM	64.15 MM	12 MM X 1.50 R.H.	NUT
Legend	91-95	5 X 114.3	MM	70.10 MM	12 MM X 1.50 R.H.	NUT
Integra Type "R"	97-on	5 X 114.3	MM	64.15 MM	12 MM X 1.50 R.H.	NUT
NSX	91-on	5 X 114.3	MM	64.15 MM	12 MM X 1.50 R.H.	NUT

ALFA ROMERO						
145, 146	94-on	4 X 98	MM	58.50 MM	12 MM X 1.50 R.H.	BOLT
155	92-98	4 X 98	MM	58.50 MM	12 MM X 1.50 R.H.	BOLT
164 (4 Lug)	88-98	4 X 98	MM	58.50 MM	12 MM X 1.50 R.H.	BOLT
33	86-96	4 X 98	MM	58.50 MM	12 MM X 1.50 R.H.	BOLT
Spider	86-91	4 X 108	MM	64.15 MM F	12 MM X 1.50 R.H.	BOLT
		4 X 108	MM	70.10 MM R	12 MM X 1.50 R.H.	BOLT
GTV / Spyder	96-on	5 X 98	MM	58.50 MM	12 MM X 1.50 R.H.	BOLT
166	99-on	5 X 98	MM	58.50 MM	12 MM X 1.50 R.H.	BOLT
156, 164 (5 Lug)	98-on	5 X 98	MM	58.50 MM	12 MM X 1.50 R.H.	BOLT
GTV 3.0 (5 Lug)	80-87	5 X 98	MM	58.50 MM	12 MM X 1.50 R.H.	BOLT

AUDI						
4000S	74-84	4 X 100	MM	57.10 MM	12 MM X 1.50 R.H.	BOLT
80,	90-87	4 X 100	MM	57.10 MM	12 MM X 1.50 R.H.	BOLT
4000, Quattro, Coupe	85-on	4 X 108	MM	57.10 MM	14 MM X 1.50 R.H.	BOLT
5000 (non-turbo)	86-88	4 X 108	MM	57.10 MM	14 MM X 1.50 R.H.	BOLT
80, 90, Coupe	88-95	4 X 108	MM	57.10 MM	14 MM X 1.50 R.H.	BOLT
Cabriolet	92-on	4 X 108	MM	57.10 MM	14 MM X 1.50 R.H.	BOLT
100	89-91	4 X 108	MM	57.10 MM	14 MM X 1.50 R.H.	BOLT
T T, TTS	99-on	5 X 100	MM	57.10 MM	14 MM X 1.50 R.H.	BOLT
A4, A6, A8, S8+A142	95-on	5 X 112	MM	57.10 MM	14 MM X 1.50 R.H.	BOLT
100, 5000, Turbo,	79-on	5 X 112	MM	57.10 MM	14 MM X 1.50 R.H.	BOLT
Quattro, 200	79-on	5 X 112	MM	57.10 MM	14 MM X 1.50 R.H.	BOLT
S4, S6	90-94	5 X 112	MM	57.10 MM	14 MM X 1.50 R.H.	BOLT
5000CS	84-91	5 X 112	MM	57.10 MM	14 MM X 1.50 R.H.	BOLT

BMW						
3 Series (E21,E30)	77-91	4 X 100	MM	57.10 MM	12 MM X 1.50 R.H.	BOLT
3 Series (E36,E46)	91-03	5 X 120	MM	72.56 MM	12 MM X 1.50 R.H.	BOLT
5 Series (E28,E34)	82-96	5 X 120	MM	72.56 MM	12 MM X 1.50 R.H.	BOLT
5 Series (E39)	97-03	5 X 120	MM	74.10 MM	12 MM X 1.50 R.H.	BOLT
6 Series (E24)	77-89	5 X 120	MM	72.56 MM	12 MM X 1.50 R.H.	BOLT
7 Series (E23)	77-86	5 X 120	MM	72.56 MM	12 MM X 1.50 R.H.	BOLT
7 Series (E38)	95-01	5 X 120	MM	72.56 MM	12 MM X 1.50 R.H.	BOLT
7 Series (E65)	96-on	5 X 120	MM	72.56 MM	14 MM X 1.50 R.H.	BOLT
M Coupe/Roadster	00-03	5 X 120	MM	72.56 MM	12 MM X 1.50 R.H.	BOLT
M3 (E30)	88-91	5 X 120	MM	72.56 MM	12 MM X 1.50 R.H.	BOLT
M3 (E36,E46)	95-03	5 X 120	MM	72.56 MM	12 MM X 1.50 R.H.	BOLT
M5 (E39)	00-03	5 X 120	MM	74.10 MM	12 MM X 1.50 R.H.	BOLT

Prestige
WHEEL ACCESSORIES

(800) 854-6770 (877) LUG-NUTS

(714) 841-6333

5 8 4 - 6 8 8 7

Fax: (714) 841-6413

M-F 7:30AM - 4:30PM CALIF TIME

APPLICATION GUIDE

CAR APPLICATION GUIDE

MAKE/MODEL	YEAR	BOLT CIRCLE	HUB BORE	LUG SIZE	LUG TYPE	NOTES
BUICK						
Skylark, Skyhawk	81-92	5 X 100	MM 57.10 MM	12 MM X 1.50 R.H.	NUT	
Regal	85-88	5 X 100	MM 57.10 MM	12 MM X 1.50 R.H.	NUT	
Century	80-86	5 X 100	MM 57.10 MM	12 MM X 1.50 R.H.	NUT	
Regal	88-on	5 X 115	MM 70.30 MM	12 MM X 1.50 R.H.	NUT	
Century, La Sabre	86-on	5 X 115	MM 70.30 MM	12 MM X 1.50 R.H.	NUT	
Reatta, Park Ave. & Electra	85-on	5 X 115	MM 70.30 MM	12 MM X 1.50 R.H.	NUT	
Regal, Riviera	89-on	5 X 115	MM 70.30 MM	12 MM X 1.50 R.H.	NUT	
Regal	77-81	5 X 120.6	MM 70.30 MM	7/16 R.H.	NUT	
Grand National	85-88	5 X 120.6	MM 70.30 MM	7/16 R.H.	NUT	
Riviera	79-85	5 X 120.6	MM 70.30 MM	7/16 R.H.	NUT	

CADILLAC						
Catera	96-on	5 X 110	MM 65.07MM	12 MM X 1.50 R.H.	BOLT	
Alante	87-94	5 X 115	MM 70.30MM	12 MM X 1.50 R.H.	NUT	
Deville, Seville & El Dorado	85-on	5 X 115	MM 70.30MM	12 MM X 1.50 R.H.	NUT	
STS, SLS, Fleetwood	85-on	5 X 115	MM 70.30MM	12 MM X 1.50 R.H.	NUT	
Deville Concourse, DHS & DTS	94-on	5 X 115	MM 70.30MM	12 MM X 1.50 R.H.	NUT	
CTS	2003	5 X 115	MM 70.30MM	12 MM X 1.50 R.H.	NUT	

CHRYSLER CORP						
EAGLE - Summit	93-on	4 X 100	MM 57.10 MM	12 MM X 1.50 R.H.	NUT	
LeBaron, New Yorker	81-85	4 X 100	MM 57.10 MM	12 MM X 1.50 R.H.	NUT	
Laser	84-86	4 X 100	MM 57.10 MM	12 MM X 1.50 R.H.	NUT	
Horizon, TC-3	78-90	4 X 100	MM 57.10 MM	12 MM X 1.50 R.H.	NUT	
Eagle Summit	89-92	4 X 114.3	MM 67.10 MM	12 MM X 1.50 R.H.	NUT	
Vista	85-94	4 X 114.3	MM 67.10 MM	12 MM X 1.50 R.H.	NUT	
Chrysler - PT Cruiser	00-on	5 X 100	MM 57.10 MM	12 MM X 1.50 R.H.	NUT	
Cirrus	95-01	5 X 100	MM 57.10 MM	12 MM X 1.50 R.H.	NUT	
Sebring JX (convt.)	96-on	5 X 100	MM 57.10 MM	12 MM X 1.50 R.H.	NUT	
LeBaron	86-96	5 X 100	MM 57.10 MM	12 MM X 1.50 R.H.	NUT	
New Yorker	86-93	5 X 100	MM 57.10 MM	12 MM X 1.50 R.H.	NUT	
GLH, Spirit	to-94	5 X 100	MM 57.10 MM	12 MM X 1.50 R.H.	NUT	
PLYMOUTH - Acclaim	to-93	5 X 100	MM 57.10 MM	12 MM X 1.50 R.H.	NUT	
Sundance	84-94	5 X 100	MM 57.10 MM	12 MM X 1.50 R.H.	NUT	
Breeze	96-on	5 X 100	MM 57.10 MM	12 MM X 1.50 R.H.	NUT	
Chrysler - 300M	98-on	5 X 114.3	MM 71.50 MM	12 MM X 1.50 R.H.	NUT	
New Yorker, LHS	94-on	5 X 114.3	MM 71.50 MM	12 MM X 1.50 R.H.	NUT	
Concorde	93-on	5 X 114.3	MM 71.50 MM	12 MM X 1.50 R.H.	NUT	
Town & Country	90-on	5 X 114.3	MM 71.50 MM	12 MM X 1.50 R.H.	NUT	
Eagle - Vision	93-on	5 X 114.3	MM 71.50 MM	12 MM X 1.50 R.H.	NUT	
Chrysler - Sebring LX	95-on	5 X 114.3	MM 67.10 MM	12 MM X 1.50 R.H.	NUT	
Plymouth - Laser	89-on	5 X 114.3	MM 67.10 MM	12 MM X 1.50 R.H.	NUT	
Eagle - Vision	89-94	5 X 114.3	MM 67.10 MM	12 MM X 1.50 R.H.	NUT	
Talon	89-on	5 X 114.3	MM 67.10 MM	12 MM X 1.50 R.H.	NUT	

DODGE						
Neon	To-93	4 X 100	MM 57.10 MM	12 MM X 1.50 R.H.	NUT	
Colt	93-on	4 X 100	MM 57.10 MM	12 MM X 1.50 R.H.	NUT	
Colt	86-92	4 X 114.3	MM 67.10 MM	12 MM X 1.50 R.H.	NUT	
Stratus	95-on	5 X 100	MM 57.10 MM	12 MM X 1.50 R.H.	NUT	
Neon (5 Lug)	94-on	5 X 100	MM 57.10 MM	12 MM X 1.50 R.H.	NUT	
Shadow, Daytona	86-94	5 X 100	MM 57.10 MM	12 MM X 1.50 R.H.	NUT	
Avenger	95-on	5 X 114.3	MM 67.10 MM	12 MM X 1.50 R.H.	NUT	
Stealth ES	93-97	5 X 114.3	MM 57.10 MM	12 MM X 1.50 R.H.	NUT	

Dodge Continued on next page....

APPLICATION GUIDE

CAR APPLICATION GUIDE

MAKE/MODEL	YEAR	BOLT CIRCLE	HUB BORE	LUG SIZE	LUG TYPE	NOTES
------------	------	-------------	----------	----------	----------	-------

DODGE

Dodge Continued ...

Stratus SE, RT Coupe	01-02	5 X 114.3	MM	57.10 MM	12 MM X 1.50 R.H.	NUT
Stealth RS Turbo	94-96	5 X 114.3	MM	67.10 MM	12 MM X 1.50 R.H.	NUT
Stealth RT	93-98	5 X 114.3	MM	57.10 MM	12 MM X 1.50 R.H.	NUT
Intrepid	93-on	5 X 114.3	MM	71.50 MM	12 MM X 1.50 R.H.	NUT
Viper	95-on	6 X 114.3	MM	71.50 MM	12 MM X 1.50 R.H.	NUT

FORD

Escort	91-on	4 X 100	MM	54.06 MM	12 MM X 1.50 R.H.	NUT
Aspire	94-98	4 X 100	MM	54.06 MM	12 MM X 1.50 R.H.	NUT
Focus	00-on	4 X 108	MM	63.36 MM	12 MM X 1.50 R.H.	NUT
Contour	95-00	4 X 108	MM	63.36 MM	12 MM X 1.50 R.H.	NUT
Tempo	84-94	4 X 108	MM	63.36 MM	12 MM X 1.50 R.H.	NUT
Escort GT	86-90	4 X 108	MM	63.36 MM	12 MM X 1.50 R.H.	NUT
Mustang	79-93	4 X 108	MM	63.90 MM	1/2 " R.H.	NUT
Thunderbird	80-88	4 X 108	MM	63.90 MM	1/2 " R.H.	NUT
Taurus, SHO	86-on	5 X 108	MM	63.90 MM	12 MM X 1.50 R.H.	NUT
Windstar	94-on	5 X 108	MM	63.90 MM	12 MM X 1.50 R.H.	NUT
Thunderbird	89-97	5 X 108	MM	63.90 MM	12 MM X 1.50 R.H.	NUT
Thunderbird - 17"	2002	5 X 108	MM	63.90 MM	12 MM X 1.50 R.H.	NUT
Mustang & GT	94-on	5 X 114.3	MM	70.60 MM	1/2 " R.H.	NUT
Crown Victoria, LTD	90-on	5 X 114.3	MM	70.60 MM	1/2 " R.H.	NUT

CHEVROLET

Spectrum	86-on	4 X 100	MM	54.06 MM	12 MM X 1.50 R.H.	NUT
Nova	86-on	4 X 100	MM	54.06 MM	12 MM X 1.50 R.H.	NUT
Chevette	76-87	4 X 100	MM	54.06 MM	12 MM X 1.50 R.H.	NUT
Cavalier, Celebrity	80-on	5 X 100	MM	57.10 MM	12 MM X 1.50 R.H.	NUT
Corsica, Beretta	87-on	5 X 100	MM	57.10 MM	12 MM X 1.50 R.H.	NUT
Z-24	80-on	5 X 100	MM	57.10 MM	12 MM X 1.50 R.H.	NUT
Eurosport	88-on	5 X 100	MM	57.10 MM	12 MM X 1.50 R.H.	NUT
Impala	99-on	5 X 115	MM	70.30 MM	12 MM X 1.50 R.H.	NUT
Malibu	97-on	5 X 115	MM	70.30 MM	12 MM X 1.50 R.H.	NUT
Monte Carlo	95-on	5 X 115	MM	70.30 MM	12 MM X 1.50 R.H.	NUT
Lumina	89-on	5 X 115	MM	70.30 MM	12 MM X 1.50 R.H.	NUT
Celebrity ES	86-89	5 X 115	MM	70.30 MM	12 MM X 1.50 R.H.	NUT
Corvette	68-82	5 X 120.6	MM	70.30 MM	7/16 R.H.	NUT
Camaro	67-92	5 X 120.6	MM	70.30 MM	7/16 R.H.	NUT
Corvette	84-on	5 X 120.6	MM	70.30 MM	12 MM X 1.50 R.H.	NUT
Camaro, Z28	93-on	5 X 120.6	MM	70.30 MM	12 MM X 1.50 R.H.	NUT
Chevelle, Malibu	65-88	5 X 120.6	MM	70.30 MM	12 MM X 1.50 R.H.	NUT
Monte Carlo	69-88	5 X 120.6	MM	70.30 MM	12 MM X 1.50 R.H.	NUT
Caprice	71-90	5 X 120.6	MM	70.30 MM	12 MM X 1.50 R.H.	NUT
Impala SS	95-98	5 X 5		77.70 MM	12 MM X 1.50 R.H.	NUT
Caprice Classic	91-on	5 X 5		77.70 MM	12 MM X 1.50 R.H.	NUT

GEO

GEO - Prizm	89-on	4 X 100	MM	54.06 MM	12 MM X 1.50 R.H.	NUT
Storm	90-94	4 X 100	MM	54.06 MM	12 MM X 1.50 R.H.	NUT
Metro	91-on	4 X 114.3	MM	59.61 MM	12 MM X 1.50 R.H.	NUT

Prestige
WHEEL ACCESSORIES

(800) 854-6770 (877) LUG-NUTS

(714) 841-6333

5 8 4 - 6 8 8 7

Fax: (714) 841-6413

M-F 7:30AM - 4:30PM CALIF TIME

APPLICATION GUIDE

CAR APPLICATION GUIDE

MAKE/MODEL	YEAR	BOLT CIRCLE	HUB BORE	LUG SIZE	LUG TYPE	NOTES
HONDA						
Accord	82-89	4 X 100	MM 56.15	MM 12	1.50 R.H.	NUT
Civic	80-on	4 X 100	MM 56.15	MM 12	1.50 R.H.	NUT
CRX	89-89	4 X 100	MM 56.15	MM 12	1.50 R.H.	NUT
Del Sol	93-on	4 X 100	MM 56.15	MM 12	1.50 R.H.	NUT
Prelude	82-91	4 X 100	MM 56.15	MM 12	1.50 R.H.	NUT
Accord (4 cyl)	98-on	4 X 114.3	MM 64.15	MM 12	1.50 R.H.	NUT
Accord (4 cyl)	90-97	4 X 114.3	MM 64.15	MM 12	1.50 R.H.	NUT
Prelude	92-96	4 X 114.3	MM 64.15	MM 12	1.50 R.H.	NUT
Accord (6 cyl)	98-on	5 X 114.3	MM 64.15	MM 12	1.50 R.H.	NUT
Prelude	97-on	5 X 114.3	MM 64.15	MM 12	1.50 R.H.	NUT
CR-V	95-on	5 X 114.3	MM 64.15	MM 12	1.50 R.H.	NUT
Odessey	95-on	5 X 114.3	MM 64.15	MM 12	1.50 R.H.	NUT
S-2000 (Front)	00-on	5 X 114.3	MM 70.10	MM 12	1.50 R.H.	NUT
(Rear)		5 X 114.3	MM 64.15	MM 12	1.50 R.H.	NUT
HYUNDAI						
Accent	00-on	4 X 100	MM 57.10	MM 12	1.50 R.H.	NUT
Accent	95-00	4 X 114.3	MM 67.10	MM 12	1.50 R.H.	NUT
Elantra	91-on	4 X 114.3	MM 67.10	MM 12	1.50 R.H.	NUT
Excel	88-94	4 X 114.3	MM 67.10	MM 12	1.50 R.H.	NUT
Scoupe	90-94	4 X 114.3	MM 67.10	MM 12	1.50 R.H.	NUT
Sonata	90-on	4 X 114.3	MM 67.10	MM 12	1.50 R.H.	NUT
Tiburon	97-on	4 X 114.3	MM 67.10	MM 12	1.50 R.H.	NUT
XG-300	01-on	5 X 114.3	MM 67.10	MM 12	1.50 R.H.	NUT
Trajet	00-on	5 X 114.3	MM 67.10	MM 12	1.50 R.H.	NUT
INFINITI						
G-20	90-on	4 X 114.3	MM 66.06	MM 12	1.25 R.H.	NUT
G-35	02-on	5 X 114.3	MM 66.06	MM 12	1.25 R.H.	NUT
I-30,I-35	95-on	5 X 114.3	MM 66.06	MM 12	1.25 R.H.	NUT
J-30	92-on	5 X 114.3	MM 66.06	MM 12	1.25 R.H.	NUT
M-45	2003	5 X 114.3	MM 66.06	MM 12	1.25 R.H.	NUT
Q-45	90-on	5 X 114.3	MM 66.06	MM 12	1.25 R.H.	NUT
ISUZU						
I-Mark	83-89	4 X 100	MM 56.60	MM 12	1.50 R.H.	NUT
Impulse (all)	84-92	4 X 100	MM 56.60	MM 12	1.50 R.H.	NUT
Stylus (all)	91-on	4 X 100	MM 56.60	MM 12	1.50 R.H.	NUT
JAGUAR						
S Type	99-03	5 X 108	MM 63.50	MM 1/2"	R.H.	NUT
X Type	2002	5 X 108	MM 63.50	MM 1/2"	R.H.	NUT
XJS S-Class	99-on	5 X 108	MM 67.10	MM 1/2"	R.H.	NUT
XJ series	69-98	5 X 120.6	MM 73.80	MM 1/2"	R.H.	NUT
XK-8	98-on	5 X 120.6	MM 73.80	MM 1/2"	R.H.	NUT
KIA						
Sephia	94-on	4 X 100	MM 56.15	MM 12	1.50 R.H.	NUT

APPLICATION GUIDE

CAR APPLICATION GUIDE

MAKE/MODEL	YEAR	BOLT CIRCLE	HUB BORE	LUG SIZE	LUG TYPE	NOTES
LEXUS						
ES-250	90-91	5 X 100	MM	54.06 MM	12 MM X 1.50 R.H.	NUT
LS 430	01-on	5 X 114.3	MM	60.06 MM	12 MM X 1.50 R.H.	NUT
IS 300	00-on	5 X 114.3	MM	60.06 MM	12 MM X 1.50 R.H.	NUT
ES 300	92-on	5 X 114.3	MM	60.06 MM	12 MM X 1.50 R.H.	NUT
GS 300	93-on	5 X 114.3	MM	60.06 MM	12 MM X 1.50 R.H.	NUT
GS 400	98-on	5 X 114.3	MM	60.06 MM	12 MM X 1.50 R.H.	NUT
LS 400	90-93	5 X 114.3	MM	60.06 MM	12 MM X 1.50 R.H.	NUT
LS 400	95-on	5 X 114.3	MM	60.06 MM	12 MM X 1.50 R.H.	NUT
SC 300	92-on	5 X 114.3	MM	60.06 MM	12 MM X 1.50 R.H.	NUT
SC 400	92-on	5 X 114.3	MM	60.06 MM	12 MM X 1.50 R.H.	NUT
SC 430 (18" only)	94-on	5 X 114.3	MM	60.06 MM	12 MM X 1.50 R.H.	NUT
LINCOLN						
Continental	88-on	5 X 108	MM	63.90 MM	12 MM X 1.50 R.H.	NUT
L/S - 16"	99-on	5 X 108	MM	63.90 MM	12 MM X 1.50 R.H.	NUT
Mark VIII	93-on	5 X 108	MM	63.90 MM	12 MM X 1.50 R.H.	NUT
Mark VII	86-92	5 X 114.3	MM	70.60 MM	1/2 " R.H.	NUT
Towncar	86-on	5 X 114.3	MM	70.60 MM	1/2 " R.H.	NUT
LSC	88-92	5 X 114.3	MM	70.60 MM	1/2 " R.H.	NUT
Grand Marquis	90-96	5 X 114.3	MM	70.60 MM	1/2 " R.H.	NUT
MAZDA						
Miata (MX-5)	90-on	4 X 100	MM	54.06 MM	12 MM X 1.50 R.H.	NUT
MX-3, GS	92-on	4 X 100	MM	54.06 MM	12 MM X 1.50 R.H.	NUT
323	90-on	4 X 100	MM	54.06 MM	12 MM X 1.50 R.H.	NUT
MX-3, GS	90-on	4 X 100	MM	54.06 MM	12 MM X 1.50 R.H.	NUT
Protégé	90-on	4 X 100	MM	54.06 MM	12 MM X 1.50 R.H.	NUT
GLC	81-85	4 X 114.3	MM	59.61 MM	12 MM X 1.50 R.H.	NUT
323,	84-89	4 X 114.3	MM	59.61 MM	12 MM X 1.50 R.H.	NUT
626, RX-7 GSL-SE	83-88	4 X 114.3	MM	59.61 MM	12 MM X 1.50 R.H.	NUT
MX-6, 626	92-on	5 X 114.3	MM	67.10 MM	12 MM X 1.50 R.H.	NUT
MX-6, 626	88-91	5 X 114.3	MM	59.61 MM	12 MM X 1.50 R.H.	NUT
Millenia, Millenia S	97-on	5 X 114.3	MM	67.10 MM	12 MM X 1.50 R.H.	NUT
929	88-94	5 X 114.3	MM	67.10 MM	12 MM X 1.50 R.H.	NUT
RX-7	89-on	5 X 114.3	MM	67.10 MM	12 MM X 1.50 R.H.	NUT
MPV	98-on	5 X 114.3	MM	67.10 MM	12 MM X 1.50 R.H.	NUT
MERCEDES						
All Models		5 X 112	MM	66.56 MM	12 MM X 1.50 R.H.	BOLT See Mercedes Benz
		5 X 112	MM	66.56 MM	14 MM X 1.50 R.H.	BOLT bolt chart on page#84
MERCURY						
Tracer	91-on	4 X 100	MM	54.06 MM	12 MM X 1.50 R.H.	NUT
Cougar	80-88	4 X 108	MM	63.90 MM	12 MM X 1.50 R.H.	NUT
Marquis, Monarch	83-86	4 X 108	MM	63.90 MM	12 MM X 1.50 R.H.	NUT
Mystique	95-on	4 X 108	MM	63.36 MM	12 MM X 1.50 R.H.	NUT
EXP, Lynx	86-90	4 X 108	MM	63.36 MM	12 MM X 1.50 R.H.	NUT
Topaz	84-94	4 X 108	MM	63.36 MM	12 MM X 1.50 R.H.	NUT
Tracer	86-90	4 X 114.3	MM	59.61 MM	12 MM X 1.50 R.H.	NUT
Capri, XR-2	91-94	4 X 114.3	MM	59.61 MM	12 MM X 1.50 R.H.	NUT
Sable	86-on	5 X 108	MM	63.90 MM	12 MM X 1.50 R.H.	NUT
Cougar	98-02	5 X 108	MM	63.90 MM	12 MM X 1.50 R.H.	NUT

APPLICATION GUIDE

CAR APPLICATION GUIDE

MAKE/MODEL	YEAR	BOLT CIRCLE	HUB BORE	LUG SIZE	LUG TYPE	NOTES
------------	------	-------------	----------	----------	----------	-------

MINI COOPER

Mini Cooper	02-03	4 X 100	MM	56.15 MM	12 MM X 1.50 R.H.	BOLT
-------------	-------	---------	----	----------	-------------------	------

MITSUBISHI

Mirage	93-00	4 X 100	MM	56.15 MM	12 MM X 1.50 R.H.	NUT
Cordia, Tredia	82-92	4 X 114.3	MM	67.10 MM	12 MM X 1.50 R.H.	NUT
Mirage	88-92	4 X 114.3	MM	67.10 MM	12 MM X 1.50 R.H.	NUT
Precis	88-94	4 X 114.3	MM	67.10 MM	12 MM X 1.50 R.H.	NUT
Galant	83-97	4 X 114.3	MM	67.10 MM	12 MM X 1.50 R.H.	NUT
Starion	82-87	4 X 114.3	MM	67.10 MM	12 MM X 1.50 R.H.	NUT
Spyder GS / GS-T	00-on	5 X 114.3	MM	67.10 MM	12 MM X 1.50 R.H.	NUT
EVO	93-on	5 X 114.3	MM	67.10 MM	12 MM X 1.50 R.H.	NUT
Eclipse	89-on	5 X 114.3	MM	67.10 MM	12 MM X 1.50 R.H.	NUT
Diamante	91-on	5 X 114.3	MM	67.10 MM	12 MM X 1.50 R.H.	NUT
Galant	99-on	5 X 114.3	MM	67.10 MM	12 MM X 1.50 R.H.	NUT
3000GT, SL (no VR-4)	91-99	5 X 114.3	MM	67.10 MM	12 MM X 1.50 R.H.	NUT

NISSAN

200 SX	95-on	4 X 100	MM	59.20 MM	12 MM X 1.25 R.H.	NUT
Sentra	87-99	4 X 100	MM	59.20 MM	12 MM X 1.25 R.H.	NUT
NX-1600	91-on	4 X 100	MM	59.20 MM	12 MM X 1.25 R.H.	NUT
NX-2000	91-93	4 X 100	MM	59.20 MM	12 MM X 1.25 R.H.	NUT
Pulsar	87-90	4 X 100	MM	59.20 MM	12 MM X 1.25 R.H.	NUT
Altima	93-01	4 X 114.3	MM	66.06 MM	12 MM X 1.25 R.H.	NUT
Maxima	79-88	4 X 114.3	MM	66.06 MM	12 MM X 1.25 R.H.	NUT
200SX	80-89	4 X 114.3	MM	66.06 MM	12 MM X 1.25 R.H.	NUT
240SX	89-95	4 X 114.3	MM	66.06 MM	12 MM X 1.25 R.H.	NUT
Stanza	79-92	4 X 114.3	MM	66.06 MM	12 MM X 1.25 R.H.	NUT
240Z, 260Z, 280Z	70-85	4 X 114.3	MM	66.06 MM	12 MM X 1.25 R.H.	NUT
300ZX (4 Lug)	84-87	4 X 114.3	MM	66.06 MM	12 MM X 1.25 R.H.	NUT
Sentra	00-on	4 X 114.3	MM	66.06 MM	12 MM X 1.25 R.H.	NUT
240SX, SE	95-98	4 X 114.3	MM	66.06 MM	12 MM X 1.25 R.H.	NUT
300ZX Turbo	84-on	5 X 114.3	MM	66.06 MM	12 MM X 1.25 R.H.	NUT
350 Z	02-on	5 X 114.3	MM	66.06 MM	12 MM X 1.25 R.H.	NUT
Maxima	89-on	5 X 114.3	MM	66.06 MM	12 MM X 1.25 R.H.	NUT
240SX	95-99	5 X 114.3	MM	66.06 MM	12 MM X 1.25 R.H.	NUT
200SX 6 cylinder	87-88	5 X 114.3	MM	66.06 MM	12 MM X 1.25 R.H.	NUT
Altima	02	5 X 114.3	MM	66.06 MM	12 MM X 1.25 R.H.	NUT
Quest	93-on	5 X 114.3	MM	66.06 MM	12 MM X 1.25 R.H.	NUT

OLDSMOBILE

Achieva	89-on	5 X 100	MM	57.10 MM	12 MM X 1.50 R.H.	NUT
Skyhawk	89-93	5 X 100	MM	57.10 MM	12 MM X 1.50 R.H.	NUT
Alero	98-02	5 X 115	MM	70.30 MM	12 MM X 1.50 R.H.	NUT
Toronado, Trofeo	89-92	5 X 115	MM	70.30 MM	12 MM X 1.50 R.H.	NUT
Cutlass Supreme, 88, 9890-on		5 X 115	MM	70.30 MM	12 MM X 1.50 R.H.	NUT
98 Royale	89-on	5 X 115	MM	70.30 MM	12 MM X 1.50 R.H.	NUT
Aurora	94-on	5 X 115	MM	70.30 MM	12 MM X 1.50 R.H.	NUT
Silhouette	90-on	5 X 115	MM	70.30 MM	12 MM X 1.50 R.H.	NUT

APPLICATION GUIDE

CAR APPLICATION GUIDE

MAKE/MODEL	YEAR	BOLT CIRCLE	HUB BORE	LUG SIZE	LUG TYPE	NOTES
------------	------	-------------	----------	----------	----------	-------

PLYMOUTH

Acclaim	86-93	5 X 100	MM	57.10 MM	12 MM X 1.50 R.H.	NUT
Sundance	84-94	5 X 100	MM	57.10 MM	12 MM X 1.50 R.H.	NUT
Breeze	96-00	5 X 100	MM	57.10 MM	12 MM X 1.50 R.H.	NUT
Voyager	96-00	5 X 100	MM	57.10 MM	12 MM X 1.50 R.H.	NUT
Voyager (4-cyl)	86-95	5 X 100	MM	57.10 MM	12 MM X 1.50 R.H.	NUT
Laser	89-94	5 X 114.3	MM	57.10 MM	12 MM X 1.50 R.H.	NUT
Grand Voyager	88-95	5 X 114.3	MM	71.50 MM	12 MM X 1.50 R.H.	NUT
Town & Country	90-01	5 X 114.3	MM	71.50 MM	12 MM X 1.50 R.H.	NUT

PONTIAC

Grand Am	89-96	5 X 100	MM	57.10 MM	12 MM X 1.50 R.H.	NUT
Sunbird	85-94	5 X 100	MM	57.10 MM	12 MM X 1.50 R.H.	NUT
Sunfire	95-on	5 X 100	MM	57.10 MM	12 MM X 1.50 R.H.	NUT
Grand Am	89-98	5 X 100	MM	57.10 MM	12 MM X 1.50 R.H.	NUT
Vibe	02	5 X 100	MM	57.10 MM	12 MM X 1.50 R.H.	NUT
Grand Prix	89-02	5 X 115	MM	70.30 MM	12 MM X 1.50 R.H.	NUT
Bonneville	87-on	5 X 115	MM	70.30 MM	12 MM X 1.50 R.H.	NUT
Grand Am	99-02	5 X 115	MM	70.30 MM	12 MM X 1.50 R.H.	NUT
Transport Van,	90-02	5 X 115	MM	70.30 MM	12 MM X 1.50 R.H.	NUT
MontanaAztek	01	5 X 115	MM	70.30 MM	12 MM X 1.50 R.H.	NUT
Firebird, Trans Am	93-on	5 X 120.6	MM	70.30 MM	12 MM X 1.50 R.H.	NUT

PORSCHE

911 , 996 , BOXTER	ALL	5 X 130	MM	72.0 MM	14 MM X 1.50 R.H.	NUT('66-'95) BOLT('96-on)
--------------------	-----	---------	----	---------	-------------------	---------------------------

SAAB

900, 900 Turbo,	88-93	4 X 108	MM	65.10 MM	14 MM X 1.50 R.H.	NUT
9000,	86-98	4 X 108	MM	65.10 MM	14 MM X 1.50 R.H.	NUT
99, 900, 900 Turbo	79-87	4 X 114.3	MM	65.10 MM	1/2 " R.H.	NUT
900, 9-3	94-on	5 X 110	MM	65.10 MM	12 MM X 1.50 R.H.	BOLT
9-5	98-on	5 X 110	MM	65.10 MM	12 MM X 1.50 R.H.	BOLT

SATURN

SC-Coupe (all)	91-on	4 X 100	MM	57.10 MM	12 MM X 1.50 R.H.	NUT
SL-4-Door (all)	91-on	4 X 100	MM	57.10 MM	12 MM X 1.50 R.H.	NUT
SW-Wagon (all)	91-on	5 X 110	MM	57.10 MM	12 MM X 1.50 R.H.	NUT
LS,LW Luxury Sedan	00-02	5 X 110	MM	65.10 MM	12 MM X 1.50 R.H.	NUT
Vue	02	5 X 110	MM	70.30 MM	12 MM X 1.50 R.H.	NUT

SUBARU

Justy	90-94	4 X 100	MM	56.15 MM	12 MM X 1.25 R.H.	NUT
Legacy	90-on	5 X 100	MM	56.15 MM	12 MM X 1.25 R.H.	NUT
Impreza	93-on	5 X 100	MM	56.15 MM	12 MM X 1.25 R.H.	NUT
Outback	90-on	5 X 100	MM	56.15 MM	12 MM X 1.25 R.H.	NUT
Forester	97-on	5 X 100	MM	56.15 MM	12 MM X 1.25 R.H.	NUT
SVX	91-on	5 X 114.3	MM	56.15 MM	12 MM X 1.25 R.H.	NUT

SUZUKI

Esteem	95-on	4 X 100	MM	54.06 MM	12 MM X 1.25 R.H.	NUT
Swift	89-on	4 X 114.3	MM	60.06 MM	12 MM X 1.25 R.H.	NUT

APPLICATION GUIDE

CAR APPLICATION GUIDE

MAKE/MODEL	YEAR	BOLT CIRCLE	HUB BORE	LUG SIZE	LUG TYPE	NOTES
------------	------	-------------	----------	----------	----------	-------

TOYOTA

Celica GT, ST, Conv	86-91	4 X 100	MM	54.06 MM	12 MM X 1.50 R.H.	NUT
Corolla	89-on	4 X 100	MM	54.06 MM	12 MM X 1.50 R.H.	NUT
GTS	87-on	4 X 100	MM	54.06 MM	12 MM X 1.50 R.H.	NUT
MR-2,	86-90	4 X 100	MM	54.06 MM	12 MM X 1.50 R.H.	NUT
Matrix	2003	5 X 100	MM	54.06 MM	12 MM X 1.50 R.H.	NUT
Paseo	92-on	5 X 100	MM	54.06 MM	12 MM X 1.50 R.H.	NUT
Tercel	89-on	5 X 100	MM	54.06 MM	12 MM X 1.50 R.H.	NUT
Camry	83-91	5 X 100	MM	54.06 MM	12 MM X 1.50 R.H.	NUT
Celica GT-S	86-on	5 X 100	MM	54.06 MM	12 MM X 1.50 R.H.	NUT
Celica ST, GT, Conv	92-on	5 X 100	MM	54.06 MM	12 MM X 1.50 R.H.	NUT
Avalon	95-on	5 X 114.3	MM	60.06 MM	12 MM X 1.50 R.H.	NUT
Camary Solara	99-on	5 X 114.3	MM	60.06 MM	12 MM X 1.50 R.H.	NUT
Camary	92-on	5 X 114.3	MM	60.06 MM	12 MM X 1.50 R.H.	NUT
Cressida	89-92	5 X 114.3	MM	60.06 MM	12 MM X 1.50 R.H.	NUT
MR-2, MR-2 Turbo	90-95	5 X 114.3	MM	60.06 MM	12 MM X 1.50 R.H.	NUT
Supra (non-Turbo)	86-92	5 X 114.3	MM	60.06 MM	12 MM X 1.50 R.H.	NUT

VOLKSWAGEN

Golf II, III	85-on	4 X 100	MM	57.10 MM	12 MM X 1.50 R.H.	BOLT
Jetta II, III	85-98	4 X 100	MM	57.10 MM	12 MM X 1.50 R.H.	BOLT
Passat (4-cyl)	90-94	4 X 100	MM	57.10 MM	12 MM X 1.50 R.H.	BOLT
Cabriolet (all)	80-on	4 X 100	MM	57.10 MM	12 MM X 1.50 R.H.	BOLT
Fox	87-93	4 X 100	MM	57.10 MM	12 MM X 1.50 R.H.	BOLT
Corrado G-60	89-92	4 X 100	MM	57.10 MM	12 MM X 1.50 R.H.	BOLT
Scirocco (all)	76-89	4 X 100	MM	57.10 MM	12 MM X 1.50 R.H.	BOLT
Golf III, GTI, VR-6	93-on	5 X 100	MM	57.10 MM	12 MM X 1.50 R.H.	BOLT
Jetta III VR-6	93-98	5 X 100	MM	57.10 MM	14 MM X 1.50 R.H.	BOLT
Jetta IV	99-on	5 X 100	MM	57.10 MM	14 MM X 1.50 R.H.	BOLT
Passat GLX VR-6	92-96	5 X 100	MM	57.10 MM	14 MM X 1.50 R.H.	BOLT
Corrado VR-6	93-on	5 X 100	MM	57.10 MM	14 MM X 1.50 R.H.	BOLT
Beetle (14x1.5B)	98-on	5 X 100	MM	57.10 MM	14 MM X 1.50 R.H.	BOLT
Passat	98-on	5 X 112	MM	57.10 MM	14 MM X 1.50 R.H.	BOLT

VOLVO

850 Series (4 lug)	91-93	4 X 108	MM	65.10 MM	12 MM X 1.75 R.H.	BOLT
850, 960	94-98	5 X 108	MM	65.10 MM	12 MM X 1.75 R.H.	BOLT
C70, S70, V70	98-on	5 X 108	MM	65.10 MM	12 MM X 1.75 R.H.	BOLT
S90, V90	97-03	5 X 108	MM	65.10 MM	12 MM X 1.75 R.H.	BOLT
S80	99-03	5 X 108	MM	65.10 MM	12 MM X 1.75 R.H.	BOLT
700 Series	88-93	5 X 108	MM	65.10 MM	12 MM X 1.50 R.H.	BOLT
940 Series	91-94	5 X 108	MM	65.10 MM	12 MM X 1.50 R.H.	BOLT
XC90	03-on	5 X 108	MM	65.10 MM	12 MM X 1.75 R.H.	BOLT

Prestige
WHEEL ACCESSORIES

(800) 854-6770 (877) LUG-NUTS

(714) 841-6333

Fax: (714) 841-6413

5 8 4 - 6 8 8 7

M-F 7:30AM - 4:30PM CALIF TIME

APPLICATION GUIDE

TRUCK / SUV APPLICATION GUIDE

MAKE/MODEL	YEAR	BOLT CIRCLE	HUB BORE	LUG SIZE	LUG TYPE	NOTES
ACURA						
SLX	96-on	6 X 5.5	108.00	MM	12 MM X 1.50 R.H.	NUT
MDX	01-on	5 X 114.3	64.10	MM	12 MM X 1.50 R.H.	NUT
BMW						
X 5	00-on	5 X 120	72.56	MM	14 MM X 1.50 R.H.	BOLT
CADILLAC						
CADILLAC - Escalade	98-on	6 X 5.5	78.03	MM	14 MM X 1.50 R.H.	NUT
CHEVROLET						
2wd S10, Sonoma	82-on	5 X 4.75	70.30	MM	12 MM X 1.50 R.H.	NUT
Blazer, Jimmy - 2wd	95-01	5 X 4.75	70.30	MM	12 MM X 1.50 R.H.	NUT
S-10, T-15, 2wd	82-on	5 X 4.75	70.30	MM	12 MM X 1.50 R.H.	NUT
4wd S10, Sonoma	82-01	5 X 4.75	70.30	MM	12 MM X 1.50 R.H.	NUT
Blazer, Jimmy - 4wd	95-01	5 X 4.75	70.30	MM	12 MM X 1.50 R.H.	NUT
S-10, T-15, 4wd	83-on	5 X 4.75	70.30	MM	12 MM X 1.50 R.H.	NUT
Chevy Astro	85-on	5 X 5.0	77.80	MM	1/2" RH	NUT
Suburban	71-87	5 X 5.0	77.80	MM	1/2" RH	NUT
C10, E10, G10,	71-87	5 X 5.0	77.80	MM	1/2" RH	NUT
P10, G20						
2wd C1500 (std height)	88-98	5 X 5.0	77.80	MM	14 MM X 1.50 R.H.	NUT
Tahoe, Yukon 1/2 TON	95-on	5 X 5.0	77.80	MM	14 MM X 1.50 R.H.	NUT
Blazer Full Size 2wd	92-94	5 X 5.0	77.80	MM	14 MM X 1.50 R.H.	NUT
Savannah Van	01-on	5 X 5.0	77.80	MM	14 MM X 1.50 R.H.	NUT
Chevrolet - Trail Blazer	01-on	6 X 5.0	78.03	MM	12 MM X 1.50 R.H.	NUT
C/K 1500 2/4wd	99-01	6 X 5.5	78.03	MM	14 MM X 1.50 R.H.	NUT
Silverado 2/4wd	99-on	6 X 5.5	78.03	MM	14 MM X 1.50 R.H.	NUT
Sierra 2/4wd	99-on	6 X 5.5	78.03	MM	14 MM X 1.50 R.H.	NUT
Avalanche	01-on	6 X 5.5	78.03	MM	14 MM X 1.50 R.H.	NUT
Tahoe, Yukon	95-on	6 X 5.5	78.03	MM	14 MM X 1.50 R.H.	NUT
Blazer-Full Size- 4wd	92-94	6 X 5.5	78.03	MM	14 MM X 1.50 R.H.	NUT
Suburban	92-on	6 X 5.5	78.03	MM	14 MM X 1.50 R.H.	NUT
K-5 Blazer	69-70	6 X 5.5	108.00	MM	7/16" RH	NUT
Blazer Full Size 2/4wd	71-91	6 X 5.5	108.00	MM	7/16" RH	NUT
4wd Suburban 1/2 ton	71-91	6 X 5.5	108.00	MM	7/16" RH	NUT
Chevy Pickups & Vans	46-70	6 X 5.5	108.00	MM	7/16" RH	NUT
Chevy Trucks/Vans 4wd	71-87	6 X 5.5	108.00	MM	7/16" RH	NUT
Suburban 2500 2/4wd	92-on	8 X 6.5	130.80	MM	14 MM X 1.50 R.H.	NUT
Chevy. & GMC 2500		8 X 6.5	130.80	MM	Duplex	NUT
2wd / 4wd	92-98	8 X 6.5	130.80	MM	Duplex	NUT
Chevy & GMC	60-87	8 X 6.5	130.80	MM	9/16" Duplex	NUT
3/4, 1 ton						
2/4wd trucks, vans,	60-87	8 X 6.5	130.80	MM	Duplex	NUT
Suburban	82-92	8 X 6.5	130.80	MM	1/2" Duplex	NUT
H2 Hummer	02-on	8 X 6.5	125.00	MM	14 MM X 1.50	NUT
CHRYSLER CORP.						
CRY.-Town&Country	88-89	5 X 100 MM	57.10	MM	12 MM X 1.50 R.H.	NUT
Voyager 4cyl	96-on	5 X 100 MM	57.10	MM	12 MM X 1.50 R.H.	NUT
Voyager	86-95	5 X 100 MM	57.10	MM	12 MM X 1.50 R.H.	NUT
w/112" wheelbase	86-95	5 X 100 MM	57.10	MM	12 MM X 1.50 R.H.	NUT
Town & Country	90-on	5 X 4.5	71.50	MM	12 MM X 1.50 R.H.	NUT
PLYMOUTH - Voyager	96-on	5 X 4.5	71.50	MM	12 MM X 1.50 R.H.	NUT
w/119" wheelbase	92-on	5 X 4.5	71.50	MM	12 MM X 1.50 R.H.	NUT
Voyager V-6	96-on	5 X 4.5	71.50	MM	12 MM X 1.50 R.H.	NUT
Pacifica	03	5 X 4.5	71.50	MM	12 MM X 1.50 R.H.	NUT

APPLICATION GUIDE

TRUCK / SUV APPLICATION GUIDE

MAKE/MODEL	YEAR	BOLT CIRCLE	HUB BORE	LUG SIZE	LUG TYPE	NOTES
DODGE						
Ram 2500	98-03	8 X 6.5	121.00	MM	9/16" RH	NUT
Caravan		5 X 100 MM	57.10	MM	12 MM X 1.50 R.H.	NUT
w/112" wheelbase	86-95	5 X 100 MM	57.10	MM	12 MM X 1.50 R.H.	NUT
Caravan 4-cyl	96-on	5 X 100 MM	57.10	MM	12 MM X 1.50 R.H.	NUT
Ram 1500 LT 2/4wd	94-01	5 X 4.5	71.50	MM	12 MM X 1.50 R.H.	NUT
DODGE-Grd Cara. SE	88-95	5 X 4.5	71.50	MM	12 MM X 1.50	NUT
Caravan V-6	96-on	5 X 4.5	71.50	MM	12 MM X 1.50	NUT
DODGE - Truck	2002	5 X 5.5	78.03	MM	9/16" RH	NUT
1/2 & 3/4 Ton						
DODGE - Truck	85-01	5 X 5.5	108.00	MM	1/2" RH	NUT
1/2 & 3/4 Ton						
Pickup & Van 2wd / 4wd		5 X 5.5	108.00	MM	1/2" RH	NUT
A-100, B-100, D-100,	74-90	5 X 5.5	108.00	MM	1/2" RH	NUT
D-150		5 X 5.5	108.00	MM	1/2" RH	NUT
Ramcharger 2/4wd	93-on	5 X 5.5	108.00	MM	1/2" RH	NUT
Ram 150/S	92-93	5 X 5.5	108.00	MM	1/2" RH	NUT
Trailduster w/ lockhubs	74-85	5 X 5.5	108.00	MM	1/2" RH	NUT
DODGE-1/2 Ton T-300	94-on	5 X 5.5	108.00	MM	1/2" RH	NUT
Ram Truck	94-on	5 X 5.5	78.03	MM	1/2" RH	NUT
Ram Truck	2002	5 X 5.5	78.03	MM	9/16"RH	NUT
DODGE - Dakota	91-on	6 X 4.5	71.50	MM	1/2" RH	NUT
Durango	97-on	6 X 4.5	71.50	MM	1/2" RH	NUT
DODGE - D-50 2/4wd	79-91	6 X 5.5	108.00	MM	12 MM X 1.50	NUT

FORD						
Expedition 2 & 4 wd	97-02	5 X 135 MM	87.10	MM	14 MM X 2.00	
Windstar	95-01	5 X 4.5	63.90	MM	12 MM X 1.50	NUT
Aerostar	85-on	5 X 4.5	70.60	MM	1/2" RH	NUT
Ranger & Bronco II	All	5 X 4.5	70.60	MM	1/2" RH	NUT
FORD - Explorer	91-02	5 X 4.5	70.60	MM	1/2" RH	NUT
FORD - Escape	01-on	5 X 4.5	66.06	MM	12 MM X 1.50	NUT
MERC.-Mountaineer	96-on	5 X 4.5	70.60	MM	12 MM X 1.50	NUT
FORD - Expedition	97-on	5 X 135 MM	87.10	MM	12 MM X 1.75	NUT
F-150	97-on	5 X 135 MM	87.10	MM	12 MM X 1.75	NUT
Bronco 2wd / 4wd	66-96	5 X 5.5	87.10	MM	1/2" RH	NUT
F-100, F-150 Pickup	66-96	5 X 5.5	87.10	MM	1/2" RH	NUT
FORD-Expedition 4WD	03-on	6 X 135 MM	87.10	MM	14 MM X 2.0	NUT
F-150 - 4WD	01-on	5 X 135 MM	87.10	MM	14 MM X 2.0	NUT
F-250	97-98	7 X 150 MM	87.10	MM	12 MM X 1.75	NUT
F-250 Super Duty	98-on	8 X 170 MM	125.22	MM	14 MM X 2.0	NUT
F-250, F-350 Pickup	70-96	8 X 6.5	130.80	MM	1/2" Duplex	NUT
E-250, E-350 Van	70-96	8 X 6.5	130.80	MM	1/2" or 9/16"	NUT

HUMMER						
H2	02-on	8 X 6.5	125.00	MM	14 MM X 1.50	NUT

HYUNDAI						
Santa Fe	00-on	5 X 4.5	67.10	MM	12 MM X 1.50	NUT

GMC						
Buick - Rendevous	01-on	5 X 115 MM	70.30	MM	12 MM X 1.50	NUT
Venture	97-on	5 X 115 MM	70.30	MM	12 MM X 1.50	NUT
OLDSMOBILE-Silhou.	90-on	5 X 115 MM	70.30	MM	12 MM X 1.50	NUT
PONTIAC - Transport	90-on	5 X 115 MM	70.30	MM	12 MM X 1.50	NUT
Montana	97-on	5 X 115 MM	70.30	MM	12 MM X 1.50	NUT
Aztec	00-on	5 X 115 MM	70.30	MM	12 MM X 1.50	NUT

GMC Continued on next page...

APPLICATION GUIDE

TRUCK / SUV APPLICATION GUIDE

MAKE/MODEL	YEAR	BOLT CIRCLE	HUB BORE	LUG SIZE	LUG TYPE	NOTES
------------	------	-------------	----------	----------	----------	-------

GMC

GMC Continued...

GMC Safari	85-on	5 X 5.0	78.03	MM	1/2" RH	NUT
G.M.C. - Envoy	00-on	6 X 5.0	78.03	MM	12 MM X 1.50	NUT
Oldsmobile - Bravada	85-on	5 X 4.75	70.30	MM	12 MM X 1.50	NUT
G.M. - K1500 4wd	88-on	6 X 5.5	78.03	MM	14 MM X 1.50	NUT
GMC - Denali	98-on	6 X 5.5	78.03	MM	14 MM X 1.50	NUT

HONDA

Pilot	02-03	5 X 4.5	64.10	MM	12 MM X 1.50	NUT
CRV	97-on	5 X 4.5	64.10	MM	12 MM X 1.50	NUT
Odessey	95-on	5 X 4.5	64.10	MM	12 MM X 1.50	NUT
Passport	95-on	6 X 5.5	100.60	MM	12 MM X 1.50	NUT

ISUZU

Axiom	01-on	6 X 5.5	100.60	MM	12 MM X 1.50	NUT
Vehi-Cross - 16"	99-on	6 X 5.5	100.60	MM	12 MM X 1.50	NUT
Trooper	92-on	6 X 5.5	100.60	MM	12 MM X 1.50	NUT
Rodeo	91-on	6 X 5.5	100.60	MM	12 MM X 1.50	NUT
Trooper II	88-91	6 X 5.5	100.60	MM	12 MM X 1.50	NUT
Pickup	84-on	6 X 5.5	100.60	MM	12 MM X 1.50	NUT
Amigo 2wd & 4wd	89-on	6 X 5.5	100.60	MM	12 MM X 1.50	NUT

INFINITI

FX-35	03-on	5 X 114.3	66.06	MM	12 MM X 1.25	NUT
FX-45	03-on	5 X 114.3	66.06	MM	12 MM X 1.25	NUT
QX-4	97-on	6 X 5.5	100.60	MM	12 MM X 1.25	NUT

JEEP

Grand Cherokee 15"	80-98	5 X 4.5	71.50	MM	1/2" RH	NUT
Cherokee 15"	80-00	5 X 4.5	71.50	MM	1/2" RH	NUT
Comanche,	80-on	5 X 4.5	71.50	MM	1/2" RH	NUT
Grand Cherokee 16"	99-on	5 X 5.0	71.50	MM	1/2" RH	NUT
Wrangler, XJ	80-on	5 X 5.0	71.50	MM	1/2" RH	NUT
Jeep Liberty	01-on	5 X 5.0	71.50	MM	1/2" RH	NUT

KIA

Sportage	94-on	5 X 5.5	110.60	MM	12 MM X 1.50	NUT
----------	-------	---------	--------	----	--------------	-----

LEXUS

RX300	97-on	5 X 4.5	60.06	MM	12 MM X 1.50	NUT
LX450	96-98	6 X 5.5	110.00	MM	12 MM X 1.50	NUT
LX470	98-on	5 X 150 MM	110.00	MM	12 MM X 1.50	NUT

LINCOLN

LINCOLN - Aviator	03-on	5 X 114.30	70.60	MM	1/2" RH	NUT
LINCOLN - Nav.	98-02	5 X 135 MM	87.10	MM	12 MM X 1.75	NUT
LINCOLN - Nav.	03-on	6 X 135 MM	87.10	MM	14 MM X 2.0	NUT
LINCOLN-Blackwood	01-on	5 X 135 MM	87.10	MM	12 MM X 1.75	NUT

MAZDA

Navajo	91-95	5 X 4.5	70.60	MM	1/2" RH	NUT
Tribute	01-on	5 X 4.5	67.10	MM	12 MM X 1.50	NUT

Mazda Continued on next page...

APPLICATION GUIDE

TRUCK / SUV APPLICATION GUIDE

MAKE/MODEL	YEAR	BOLT CIRCLE	HUB BORE	LUG SIZE	LUG TYPE	NOTES
------------	------	-------------	----------	----------	----------	-------

MAZDA

Mazda Continued...

All Sport	97-on	5 X 4.5	67.10	MM	12 MM X 1.50	NUT
Tribute	01-on	5 X 4.5	67.10	MM	12 MM X 1.50	NUT
MPV Van	88-on	5 X 4.5	67.10	MM	12 MM X 1.50	NUT
Pickup, B2000, B2200	77-96	6 X 5.5	108.00	MM	12 MM X 1.50	NUT

MERCEDES BENZ

ML320 / ML420	97-on	5 X 112 MM	66.56	MM	14 MM X 1.50	BOLT
---------------	-------	------------	-------	----	--------------	------

MITSUBUISHI

Montero	83-on	6 X 5.5	106.00	MM	12 MM X 1.50	NUT
Mighty Max Pickup	83-on	6 X 5.5	106.00	MM	12 MM X 1.50	NUT

NISSAN

Quest	93-on	5 X 4.5	66.06	MM	12MM X 1.25	NUT
Pathfinder	86-on	6 X 5.5	66.06	MM	12MM X 1.25	NUT
Xterra - 16"	99-on	6 X 5.5	100.60	MM	12MM X 1.25	NUT
Frontier Pickup 4wd	98-on	6 X 5.5	100.60	MM	12MM X 1.25	NUT
Hard Body Pickup 2wd	85-on	6 X 5.5	100.60	MM	12MM X 1.25	NUT
Hard Body Pickup 4wd	85-on	6 X 5.5	100.60	MM	12MM X 1.25	NUT
Pickup 2wd	72-84	6 X 5.5	100.60	MM	12MM X 1.25	NUT
Pickup 4wd	79-84	6 X 5.5	100.60	MM	12MM X 1.25	NUT

SUBARU

Outback	95-on	5 X 100 MM	56.15	MM	12MM X 1.25	NUT
Forester	98-on	5 X 100 MM	56.15	MM	12MM X 1.25	NUT

SUZUKI

Samurai	85-96	5 X 5.5	110.60	MM	12MM X 1.25	NUT
X-90	96-on	5 X 5.5	110.60	MM	12MM X 1.25	NUT
Sidekick	89-on	5 X 5.5	110.60	MM	12MM X 1.25	NUT
Grand Viatra	99-on	5 X 5.5	110.60	MM	12MM X 1.25	NUT

TOYOTA

Pickup 2wd	69-94	5 X 4.5	67.06	MM	12MM X 1.50	NUT
High Lander - 16"	01-on	5 X 4.5	60.06	MM	12MM X 1.50	NUT
Tacoma 2wd	95-on	5 X 4.5	60.06	MM	12MM X 1.50	NUT
RAV-4	94-on	5 X 4.5	60.06	MM	12MM X 1.50	NUT
Previa	90-on	5 X 4.5	60.06	MM	12MM X 1.50	NUT
Tacoma 4wd	95-on	6 X 5.5	100.60	MM	12MM X 1.50	NUT
Sequoia 4wd	01-on	6 X 5.5	106.10	MM	12MM X 1.50	NUT
Tundra	99-on	6 X 5.5	106.10	MM	12MM X 1.50	NUT
Pickup 4wd	86-94	6 X 5.5	67.10	MM	12MM X 1.50	NUT
4-Runner	86-on	6 X 5.5	100.60	MM	12MM X 1.50	NUT
T-100	93-98	6 X 5.5	100.60	MM	12MM X 1.50	NUT
Landcruiser	69-92	6 X 5.5	108.00	MM	12MM X 1.50	NUT
Landcruiser	96-98	6 X 5.5	110.00	MM	12MM X 1.50	NUT
Landcruiser	98-on	5 X 5.5	110.00	MM	12MM X 1.50	NUT

Prestige
WHEEL ACCESSORIES

(800) 854-6770 (877) LUG-NUTS

(714) 841-6333

Fax: (714) 841-6413

5 8 4 - 6 8 8 7

M-F 7:30AM - 4:30PM CALIF TIME

DON'T DO'S

THIS CHART SHOWS DANGEROUS LUGNUT INSTALLATIONS THAT COULD RESULT IN DAMAGE, INJURY AND DEATH

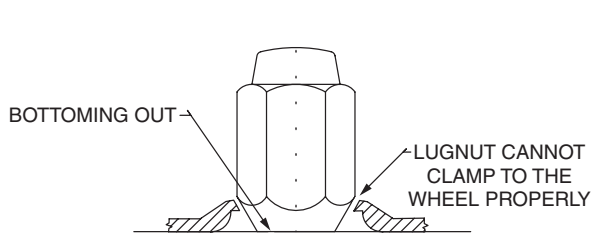

TIP TOO SMALL

When the diameter of the nut at the tip is too small or the lughole in the wheel is too large it can cause the nut to bottom out against the base of the rotor or brake drum before actually seating against the wheel.

This will prevent the wheel from being properly secured.

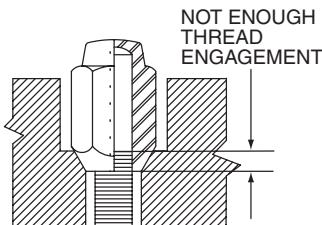

STUD TOO SHORT

When the stud is not long enough to allow for 10 full turns of thread engagement.

This often occurs when the center pad area of the wheel is extra thick and/or spacers have been used.

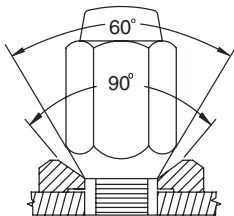

WRONG SEAT ANGLE

Never use a 60 conical seat nut on a wheel with a 90 conical seat lughole or vice versa.

There will not be enough contact surface to properly secure the wheel.

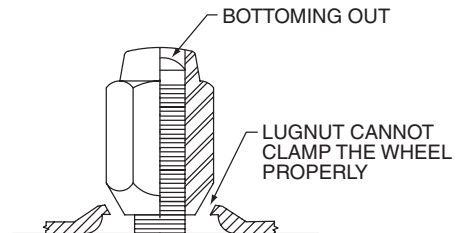

LUGNUT TOO SHORT

If the lug is not tall enough or not threaded deep enough the stud will bottom out before the nut makes proper contact with the clamping surface.

This will prevent the wheel from being properly secured.

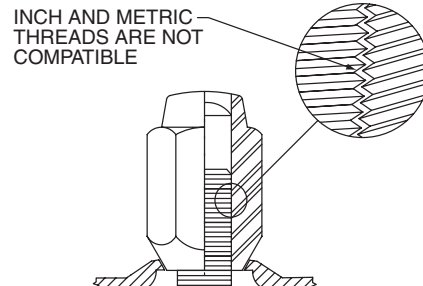

WRONG THREAD TYPE

Never try to use a metric thread nut on a US standard thread stud or vice versa.

While close

3/8 in and 10mm are not compatible
1/2 in and 12mm are not compatible
9/16 in and 14mm are not compatible

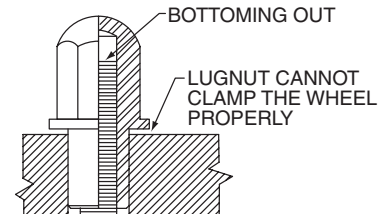

NOT ENOUGH THREAD IN THE NUT

Sometimes the nut appears tall enough but it may not be threaded deep enough.

This will cause the stud to bottom out in the top of the nut before the nut clamping surface properly mates to the clamping surface of the wheel.

A thorough understanding of this chart will greatly diminish the possibility of wheel loss due to improper lugnut installation. In order to help you understand this chart we will happily answer any question you may have.

DON'T DO'S

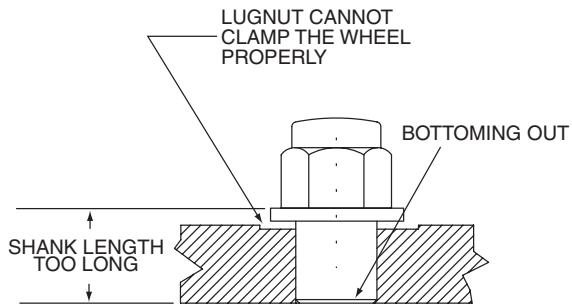

SHANK TOO LONG

The shank length of the nut is too long.

The end of the nut bottoms out against the rotor or drum surface before the nut clamping surface properly mates to the clamping surface of the wheel.

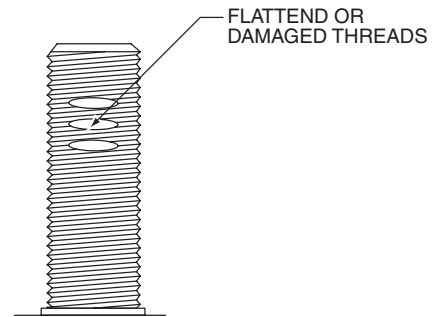

DAMAGED STUD

Damaged or flattened threads will cause the nut to seize up before proper contact of the clamping surfaces occur.

Any damaged stud must be repaired or replaced before nuts are installed.

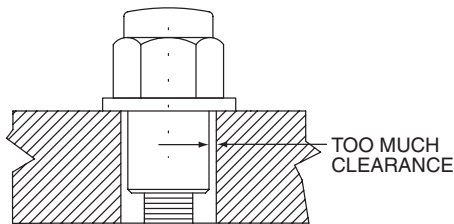

WRONG SHANK SIZE

On mag shank style applications, the diameter on the lugnut is too small. The most common cause is using a passenger car lugnut on a truck wheel.

The total clearance between the lugnut shank and the wheel hole should not exceed 1/64".

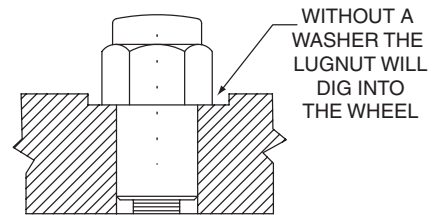

NO WASHER

Mag shank style applications must be used with a washer.

If not the shoulder of the nut will dig into the softer aluminum preventing proper clamping of the wheel.

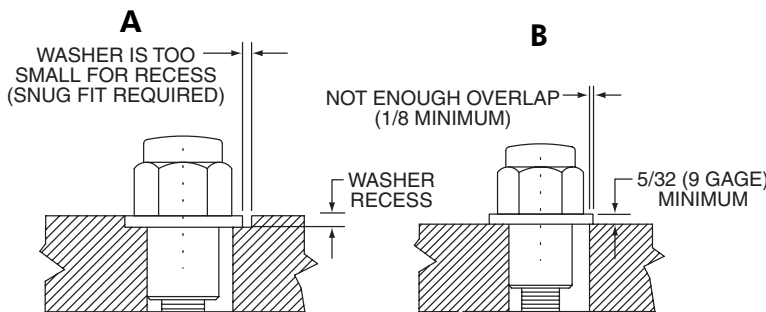

WRONG WASHER ON ELONGATED AND MULTIFIT HOLES

A) Aluminum wheels that have a specific washer recess should use a washer that was designed specifically for that recess.

The washer should fit snug and be the same shape.

Do not put a round washer in a oval hole or vice versa.

B) Wheels without a washer recess or Dual and Tri fit wheels must use a washer that overlaps the hole at least 1/8 in all around and is at least 5/32 in thick.

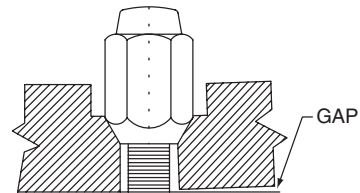

MOUNTING SURFACE INTERFERENCE

When the wheel cannot be mounted flush to the vehicle mounting surface due to some form of obstruction.

The most common is drum retainer clips, rivet heads or large calipers.

MERCEDES O.E. BOLT APPLICATION GUIDE

CHASSIS NUMBER	SERIES	YEAR	MODELS	THREAD SIZE	HEX SIZE	OVERALL LENGTH	SHANK LENGTH
W 202	C-CLASS	'93-'00	C130, C200, C220 C230, C240, C250 C280, C36, C43	12MM	17MM	60MM	39MM
W 203	C-CLASS	'00-'03	C180, C180T	12MM	17MM	60MM	39MM
W 208	CLK CLASS	'00-'03	CLK320, CLK430	12MM	17MM	70MM	39MM
W 209	CLK CLASS	2003-on	CLK320, CLK500	12MM	17MM	60MM	39MM
W 210	E CLASS	'00-'03	E320, E430	12MM	17MM	60MM	39MM
W 211	E CLASS	2003-on	E320, E430	14MM	17MM	60MM	39MM
W 215	CL CLASS	'00-'03	CL500, CL600, CL55	14MM	17MM	66MM	45MM
W 220	S CLASS	'00-'03	S320, S420, S500, S600	14MM	17MM	66MM	45MM
W 230	SL CLASS	'00-'03	SL320, SL500, SL600	14MM	17MM	45MM	27MM
W 463	G CLASS	'00-'03		14MM	17MM	66MM	45MM

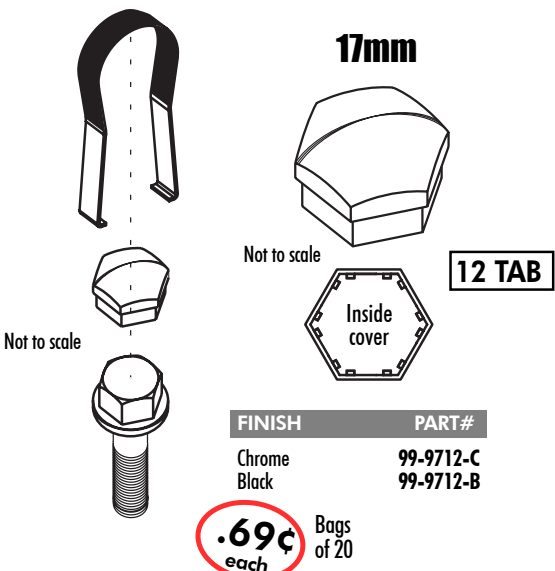

17mm

Not to scale

12 TAB

Inside cover

FINISH	PART#
Chrome	99-9712-C
Black	99-9712-B

.69¢ each Bags of 20

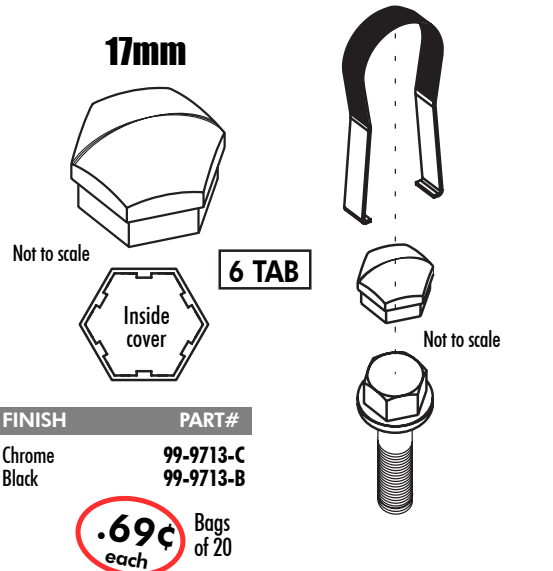

17mm

Not to scale

6 TAB

Inside cover

FINISH	PART#
Chrome	99-9713-C
Black	99-9713-B

.69¢ each Bags of 20

Bulk Pricing available for lots of 500 or more.

*Please refer to page #16 for additional information regarding lug bolt covers

Prestige
WHEEL ACCESSORIES

(800) 854-6770 (877) LUG-NUTS
5 8 4 - 6 8 8 7
(714) 841-6333
Fax: (714) 841-6413 M-F 7:30AM - 4:30PM CALIF TIME

Custom Fabrication Division

We can custom make special products for you. From rivets to body badges to centercaps. With our in house graphic and engineering departments, we can work with you from conception to delivery of product.

- Product Development
- Project Management
- Project Monitoring



- Single Contact
- Engineering & Graphic Arts
- Packaging & Delivery

A brief list of our major customers...

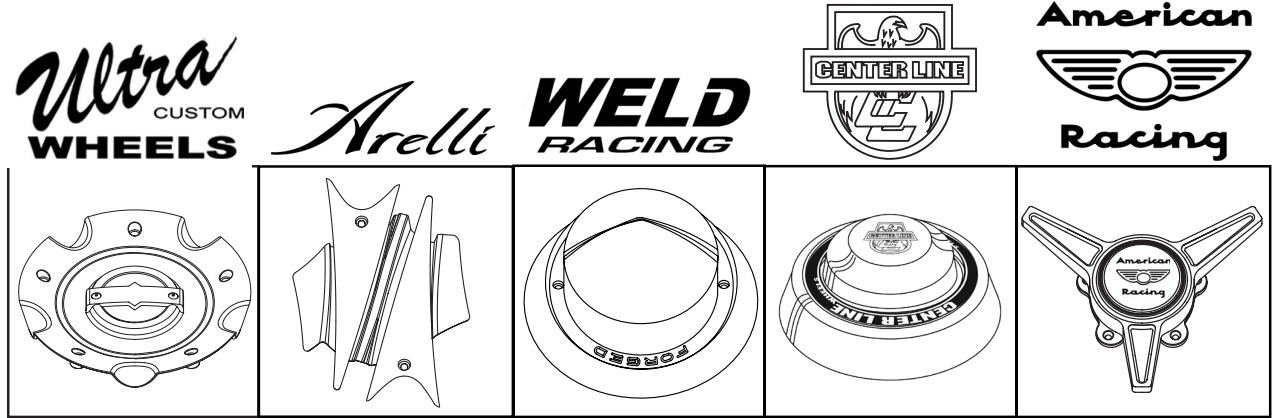

From Conception to Production

We have a knowledgeable staff of Engineers, Graphic Artists and Production Coordinators waiting to help you with your custom project from the first conception of the product to the final phases of meeting your production requirements.

With an extensive amount of experience in the automotive aftermarket business we have a wide variety of available colors, styles, designs and manufacturing capabilities to help you distinguish your style apart from the masses.

Dedicated to making overseas manufacturing... Less complicated - More profitable.

No project too big or too small. With quotes and pricing that can be customized to fit your company's needs.

We offer a variety of services and experience that can give your company the competitive edge in today's global economy.

For a more thorough brochure on our custom manufacturing capabilities and services please contact our sales department.



SUMMER/FALL 2003

Chrome Center Caps for OE Alloy Wheels

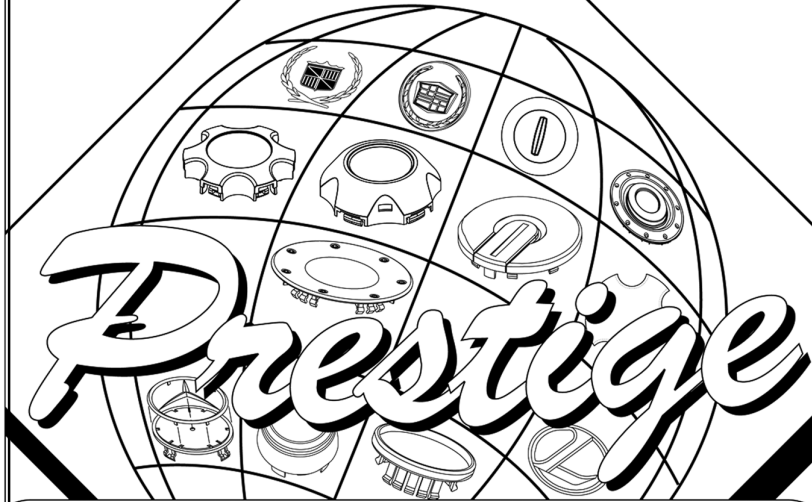

INTERNATIONAL

Call the
Sales Department
for your copy of the



Chrome Cap Guide

Prestige Wheel Accessories is the leader in chrome caps for O.E. chrome wheels.

We are adding new parts weekly.

Call your sales representative for details.

DESCRIPTION	HOLLANDER NUMBER	PRESTIGE PART NUMBER	PRICE		
CADILLAC					
ELDORADO (*92-'94)	6-5/8" PLAIN SMOOTH CAP 16x7 30 spoke For optional WREATH and/or CREST see pg #6	4508	99-450923	9.95	_____
ELDORADO (*92-'94)	7" PLAIN SMOOTH CAP 16x7 14 spoke For optional WREATH and/or CREST see pg #6	4506	99-95060	9.95	_____
ELDORADO (*95-'96)	6-5/8" PLAIN SMOOTH CAP 16x7 32 rib 16x7 14 spoke For optional WREATH and / or CREST see pg #6	4511 4512	99-450923	9.95	_____

Sorted by
ManufacturerDetailed Cap
DescriptionsHollander
Reference NumberStated Price
No Extra Price Lists

Years Listed

Optional
Cap ItemsDetailed
Wheel DescriptionOur own
Part Number

Prestige
WHEEL ACCESSORIES

(800) 854-6770 (877) LUG-NUTS

(714) 841-6333

Fax: (714) 841-6413

5 8 4 - 6 8 8 7

M-F 7:30AM - 4:30PM CALIF TIME

Everything you need to make your job easier!

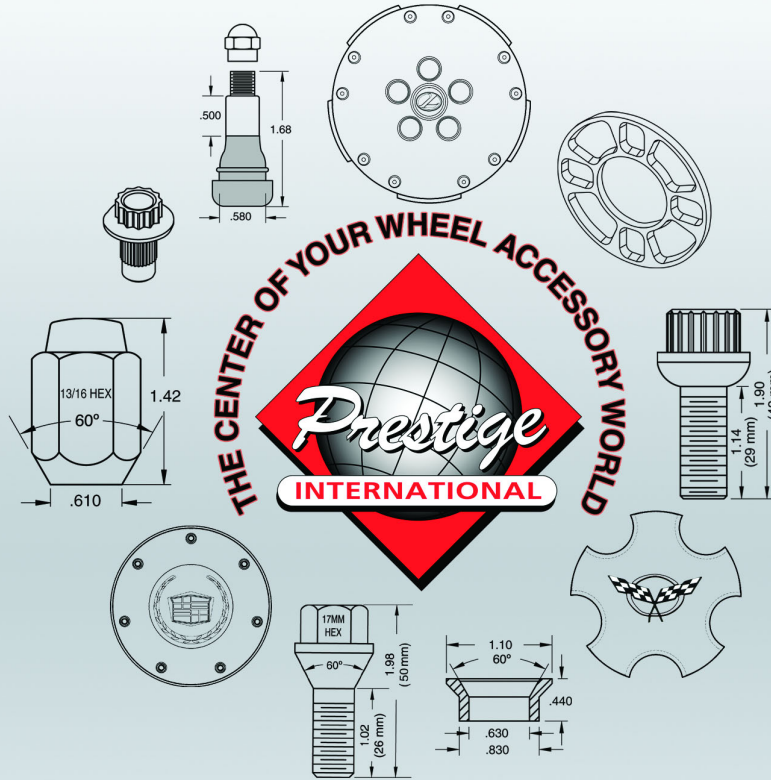

Prestige (800) 854-6770 (877) LUG-NUTS
WHEEL ACCESSORIES (714) 841-6333 5 8 4 - 6 8 8 7
Fax: (714) 841-6413 M-F 7:30AM - 4:30PM CALIF TIME

www.prestigewheel.com

Prestige
WHEEL ACCESSORIES

16892 GOTHARD STREET STE. D
HUNTINGTON BEACH, CA 92647
(714) 841-6333 (800) 854-6770

ADDRESS SERVICE REQUESTED

PRSR STD
U.S. POSTAGE
PAID
SANTA ANA, CA
PERMIT NO. 949